

Rosemount 644 Temperature Transmitter

- *Communicates easily using either 4-20 mA/HART® or FOUNDATION™ fieldbus protocol*
- *Meets NAMUR NE 21 recommendation ensuring reliable transmitter performance for head mount products*
- *The Transmitter-Sensor Matching feature improves temperature measurement accuracy by up to 75% when compared to unmatched assemblies*
- *The integral LCD Display conveniently displays the primary sensor input, and diagnostics of the transmitter*
- *An installation-ready solution that provides a variety of mounting options, transmitter configurations, and sensors/thermowells*



Contents

High Accuracy and Reliability for Control Applications	page 2
Specifications	page 3
HART and Foundation Fieldbus	page 3
Foundation Fieldbus Specifications	page 5
4–20 mA / HART Specifications	page 6
Product Certifications	page 10
Hazardous Locations Certificates	
Rosemount 644 with Foundation Fieldbus	page 10
Rosemount 644 with HART	page 12
Dimensional Drawings	page 14
Ordering Information	page 16
Configuration Data Sheet	
HART Transmitter	page 21
Foundation Fieldbus Transmitter	page 22

Rosemount 644

High Accuracy and Reliability for Control Applications

The Rosemount 644 temperature transmitter is ideal for critical applications (in many types of process environments). It provides reliability with advanced accuracy for all installations.

The Rosemount 644 can be ordered with either 4–20 mA/HART or a completely digital FOUNDATION fieldbus protocol. Each unit can be configured for a variety of sensor inputs: RTD, thermocouple, millivolt, or ohm.

DIGITAL FIELD DEVICES THAT POWER PLANTWEB



The advanced 644 powers *PlantWeb*® by communicating important temperature diagnostics and *PlantWeb* alerts to ensure process health and enable economical single-sensor architecture.

TRANSMITTER-SENSOR MATCHING

Entering the temperature-resistance profile specific to the RTD sensor into the 644 transmitter results in transmitter-sensor matching. This eliminates the sensor interchangeability error, which can improve accuracy by up to 75%.

INTEGRAL LCD DISPLAY

Local indication of temperature measurement and diagnostics provides immediate and accurate verification of process conditions.

RELIABLE TRANSMITTER PERFORMANCE

Meeting the NAMUR NE 21 recommendations, the 644 ensures top transmitter performance in harsh EMC environments. In addition, the 644 HART transmitter meets NAMUR NE 43 and NE 89 recommendations.

MOUNTING FLEXIBILITY

DIN A style head mount transmitters fits a variety of housings for remote transmitter mounting and can be integral or remote mounted to a sensor. The compact rail mount style is great for DIN rail mounting in the tight spaces of a crowded control room.

Rosemount Temperature Solutions

Rosemount 644 Temperature Transmitter

Head mount styles available with HART or FOUNDATION fieldbus protocol. Rail mount style available for HART protocol.

Rosemount 848T Eight Input Temperature Transmitter

Eight input transmitter available with FOUNDATION fieldbus protocol.

Rosemount 3420 Fieldbus Interface Module

Provides an interface between FOUNDATION fieldbus instruments and systems without fieldbus capability using standard interface protocols.

Rosemount 248 Temperature Transmitter

Head mount style (DIN B) and Rail mount style with HART protocol and complete temperature assembly.

Rosemount 144 Temperature Transmitter

Head mount style (DIN B) PC-programmable transmitter.

Rosemount sensors, thermowells, and extensions

Rosemount has a broad offering of RTD and thermocouples that are designed to meet plant requirements.

Specifications

HART AND FOUNDATION FIELDBUS

Functional Specifications

Inputs

User-selectable; sensor terminals rated to 42.4 V dc. See "Accuracy" on page 7 for sensor options.

Output

Single 2-wire device with either 4–20 mA/HART, linear with temperature or input; or a completely digital output with FOUNDATION fieldbus communication (ITK 4.5 compliant).

Isolation

Input/output isolation tested to 500 V ac rms (707 V dc) at 50/60 Hz

Local Display

The optional five-digit integral LCD Display includes a floating or fixed decimal point. It can also display engineering units (°F, °C, °R, K, Ω, and millivolts), milliampere, and percent of span. The display can be configured to alternate between selected display options. Display settings are preconfigured at the factory according to the standard transmitter configuration. They can be reconfigured in the field using either HART or FOUNDATION fieldbus communications.

Humidity Limits

0–99% relative humidity

Update Time

≤ 0.5 seconds

Accuracy (default configuration) PT 100

HART (0-100 °C): ±0.18 °C

FOUNDATION Fieldbus: ±0.15 °C

Physical Specifications

Electrical Connections

Model	Power and Sensor Terminals
644H	Compression screws permanently fixed to terminal block
644R	Compression screw permanently fixed to front panel
WAGO® Spring clamp terminals are optional (option code G5)	

HART Communicator Connections

Communication Terminals	
644H	Clips permanently fixed to terminal block
644R	Clips permanently fixed to front panel

Materials of Construction

Electronics Housing and Terminal Block	
644H	Noryl® glass reinforced
644R	Lexan® polycarbonate
Enclosure (Option code J5 or J6)	
Housing	Low-copper aluminum
Paint	Polyurethane
Cover O-ring	Buna-N

Mounting

The 644R attaches directly to a wall or a DIN rail. The 644H installs in a connection head or universal head mounted directly on a sensor assembly, apart from a sensor assembly using a universal head, or to a DIN rail using an optional mounting clip.

Weight

Code	Options	Weight
644H	HART, Head Mount Transmitter	96 g (3.39 oz)
644H	FOUNDATION fieldbus, Head Mount Transmitter	92 g (3.25 oz)
644R	HART, Rail Mount Transmitter	174 g (6.14 oz)
M5	LCD Display	38 g (1.34 oz)
J5, J6	Universal Head, Standard Cover	577 g (20.35 oz)
J5, J6	Universal Head, Meter Cover	667 g (23.53 oz)

Enclosure Ratings (644H)

All option codes (S1, S2, S3, S4, J5 and J6) are NEMA 4X, IP66, and IP68. Option code J6 is CSA Enclosure Type 4X.

Rosemount 644

Performance Specifications

EMC (ElectroMagnetic Compatibility) NAMUR NE 21 Standard

The 644H HART meets the requirements for NAMUR NE 21 Rating. (Hardware Rev 26 and later for HART devices.)

Susceptibility	Parameter	Influence
ESD	• 6 kV contact discharge	HART None
	• 8 kV air discharge	
Radiated	• 80 – 1000 MHz at 10 V/m AM	< 0.5%
Burst	• 1 kV for I.O.	None
Surge	• 0.5 kV line–line	None
	• 1 kV line–ground (I.O. tool)	
Conducted	• 150 kHz to 80 MHz at 10 V	< 0.5%

CE Mark

The 644 meets all requirements listed under IEC 61326: Amendment 1, 1998.

Power Supply Effect

Less than ±0.005% of span per volt

Stability

RTDs and thermocouples have a stability of ±0.15% of output reading or 0.15 °C (whichever is greater) for 24 months

Self Calibration

The analog-to-digital measurement circuitry automatically self-calibrates for each temperature update by comparing the dynamic measurement to extremely stable and accurate internal reference elements.

Vibration Effect

The 644 is tested to the following specifications with no effect on performance:

Frequency	Vibration
10 to 60 Hz	0.21 mm displacement
60 to 500 Hz	3 g peak acceleration

Sensor Connections

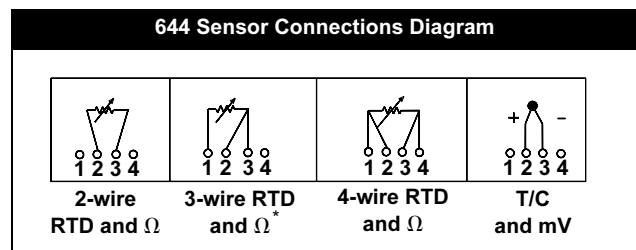

* Rosemount Inc. provides 4-wire sensors for all single element RTDs. You can use these RTDs in 3-wire configurations by leaving the unneeded leads disconnected and insulated with electrical tape.

FOUNDATION FIELDBUS SPECIFICATIONS

Function Blocks

Resource Block

- The resource block contains physical transmitter information including available memory, manufacture identification, device type, software tag, and unique identification.

Transducer Block

- The transducer block contains the actual temperature measurement data, including sensor 1 and terminal temperature. It includes information about sensor type and configuration, engineering units, linearization, reranging, damping, temperature correction, and diagnostics.

LCD Block

- The LCD block is used to configure the local display, if a LCD Display is being used.

Analog Input (AI)

- Processes the measurement and makes it available on the fieldbus segment
- Allows filtering, alarming, and engineering unit changes.

PID Block

- The transmitter provides control functionality with one PID function block in the transmitter. The PID block can be used to perform single loop, cascade, or feedforward control in the field.

Block	Execution Time (milliseconds)
Resource	–
Transducer	–
LCD Block	–
Analog Input 1	45
Analog Input 2	45
PID 1	60

Turn-on Time

Performance within specifications in less than 20 seconds after power is applied, when damping value is set to 0 seconds.

Status

If self-diagnostics detect a sensor burnout or a transmitter failure, the status of the measurement will be updated accordingly. Status may also send the PID output to a safe value.

Power Supply

Powered over FOUNDATION Fieldbus with standard fieldbus power supplies. The transmitter operates between 9.0 and 32.0 VDC, 11 mA maximum. The power terminals are rated to 42.4 VDC (max.).

Alarms

The AI function block allows the user to configure the alarms to HI-HI, HI, LO, or LO-LO with a variety of priority levels and hysteresis settings.

Backup Link Active Scheduler (LAS)

The transmitter is classified as a device link master, which means it can function as a Link Active Scheduler (LAS) if the current link master device fails or is removed from the segment.

The host or other configuration tool is used to download the schedule for the application to the link master device. In the absence of a primary link master, the transmitter will claim the LAS and provide permanent control for the H1 segment.

FOUNDATION Fieldbus Parameters

Schedule Entries	25 ⁽¹⁾
Links	16 ⁽¹⁾
Virtual Communications Relationships (VCR)	12 ⁽¹⁾

(1) Minimum quantity.

Rosemount 644

4–20 mA / HART SPECIFICATIONS

Power Supply

External power supply required. Transmitters operate on 12.0 to 42.4 V dc transmitter terminal voltage (with 250 ohm load, 18.1 V dc power supply voltage is required). Transmitter power terminals rated to 42.4 V dc.

Load Limitations

$$\text{Maximum Load} = 40.8 \times (\text{Supply Voltage} - 12.0)^{(1)}$$

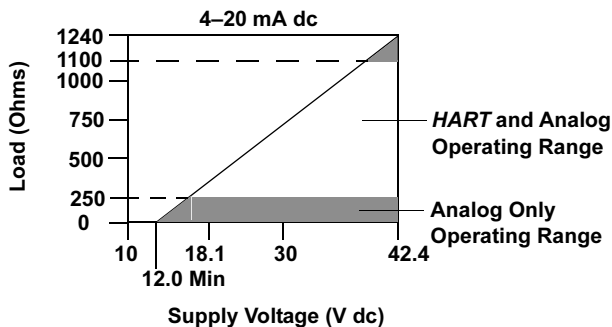

(1) Without transient protection (optional).

NOTE

HART Communication requires a loop resistance between 250 and 1100 ohms. Do not communicate with the transmitter when power is below 12 V dc at the transmitter terminals.

Temperature Limits

	Operating Limit	Storage Limit
With LCD Display	-4 to 185 °F -20 to 85 °C	-50 to 185 °F -45 to 85 °C
Without LCD Display	-40 to 185 °F -40 to 85 °C	-58 to 248 °F -50 to 120 °C

Hardware and Software Failure Mode

The 644 features software driven alarm diagnostics and an independent circuit which is designed to provide backup alarm output if the microprocessor software fails. The alarm direction (HI/LO) is user-selectable using the failure mode switch. If failure occurs, the position of the switch determines the direction in which the output is driven (HI or LO). The switch feeds into the digital-to-analog (D/A) converter, which drives the proper alarm output even if the microprocessor fails. The values at which the transmitter software drives its output in failure mode depends on whether it is configured to standard, custom, or NAMUR-compliant (NAMUR recommendation NE 43, June 1997) operation. Table 1 shows the configuration alarm ranges.

TABLE 1. Available Alarm Range⁽¹⁾

	Standard	NAMUR- NE 43 Compliant
Linear Output:	$3.9 \leq I^{(2)} \leq 20.5$	$3.8 \leq I \leq 20.5$
Fail High:	$21.75 \leq I \leq 23$	$21.5 \leq I \leq 23$
Fail Low:	$3.5 \leq I \leq 3.75$	$3.5 \leq I \leq 3.6$

(1) Measured in milliamperes.

(2) I = Process Variable (current output).

Custom Alarm and Saturation Level

Custom factory configuration of alarm and saturation level is available with option code C1 for valid values. These values can also be configured in the field using a HART Communicator.

Turn-on Time

Performance within specifications in less than 5.0 seconds after power is applied, when damping value is set to 0 seconds.

Transient Protection

The Rosemount 470 prevents damage from transients induced by lightning, welding, or heavy electrical equipment. For more information, refer to the 470 Product Data Sheet (document number 00813-0100-4191).

HART
4-20 mA

Accuracy

TABLE 2. Rosemount 644 Input Options and Accuracy.

Sensor Options	Sensor Reference	Input Ranges		Recommended Min. Span ⁽¹⁾		Digital Accuracy ⁽²⁾		D/A Accuracy ⁽³⁾
		°C	°F	°C	°F	°C	°F	
2-, 3-, 4-wire RTDs								
Pt 100	IEC 751, 1995 ($\alpha = 0.00385$)	-200 to 850	-328 to 1562	10	18	± 0.15	± 0.27	±0.03% of span
Pt 100	JIS 1604, 1981 ($\alpha = 0.003916$)	-200 to 645	-328 to 1193	10	18	± 0.15	± 0.27	±0.03% of span
Pt 200	IEC 751, 1995 ($\alpha = 0.00385$)	-200 to 850	-328 to 1562	10	18	± 0.27	± 0.49	±0.03% of span
Pt 500	IEC 751, 1995 ($\alpha = 0.00385$)	-200 to 850	-328 to 1562	10	18	± 0.19	± 0.34	±0.03% of span
Pt 1000	IEC 751, 1995 ($\alpha = 0.00385$)	-200 to 300	-328 to 572	10	18	± 0.19	± 0.34	±0.03% of span
Ni 120	Edison Curve No. 7	-70 to 300	-94 to 572	10	18	± 0.15	± 0.27	±0.03% of span
Cu 10	Edison Copper Winding No. 15	-50 to 250	-58 to 482	10	18	±1.40	± 2.52	±0.03% of span
Thermocouples ⁽⁴⁾								
Type B ⁽⁵⁾	NIST Monograph 175, IEC 584	100 to 1820	212 to 3308	25	45	± 0.77	± 1.39	±0.03% of span
Type E	NIST Monograph 175, IEC 584	-50 to 1000	-58 to 1832	25	45	± 0.20	± 0.36	±0.03% of span
Type J	NIST Monograph 175, IEC 584	-180 to 760	-292 to 1400	25	45	± 0.35	± 0.63	±0.03% of span
Type K ⁽⁶⁾	NIST Monograph 175, IEC 584	-180 to 1372	-292 to 2502	25	45	± 0.50	± 0.90	±0.03% of span
Type N	NIST Monograph 175, IEC 584	-200 to 1300	-328 to 2372	25	45	± 0.50	± 0.90	±0.03% of span
Type R	NIST Monograph 175, IEC 584	0 to 1768	32 to 3214	25	45	± 0.75	± 1.35	±0.03% of span
Type S	NIST Monograph 175, IEC 584	0 to 1768	32 to 3214	25	45	± 0.70	± 1.26	±0.03% of span
Type T	NIST Monograph 175, IEC 584	-200 to 400	-328 to 752	25	45	± 0.35	± 0.63	±0.03% of span
DIN Type L	DIN 43710	-200 to 900	-328 to 1652	25	45	± 0.35	± 0.63	±0.03% of span
DIN Type U	DIN 43710	-200 to 600	-328 to 1112	25	45	± 0.35	± 0.63	±0.03% of span
Type W5Re/W26Re	ASTM E 988-96	0 to 2000	32 to 3632	25	45	± 0.70	± 1.26	±0.03% of span
Millivolt Input		-10 to 100 mV		3 mV		±0.015 mV		±0.03% of span
2-, 3-, 4-wire Ohm Input		0 to 2000 ohms		20 ohm		±0.45 ohm		±0.03% of span

(1) No minimum or maximum span restrictions within the input ranges. Recommended minimum span will hold noise within accuracy specification with damping at zero seconds.

(2) The published digital accuracy applies over the entire sensor input range. Digital output can be accessed by HART or FOUNDATION fieldbus Communications or Rosemount control system.

(3) Total Analog accuracy is the sum of digital and D/A accuracies. This is not applicable for FOUNDATION Fieldbus

(4) Total digital accuracy for thermocouple measurement: sum of digital accuracy +0.5 °C. (cold junction accuracy)

(5) Digital accuracy for NIST Type B T/C is ±3.0 °C (±5.4 °F) from 100 to 300 °C (212 to 572 °F).

(6) Digital accuracy for NIST Type K T/C is ±0.70 °C (±1.26 °F) from -180 to -90 °C (-292 to -130 °F).

Accuracy Example (HART devices)

When using a Pt 100 ($\alpha = 0.00385$) sensor input with a 0 to 100 °C span:

- Digital accuracy = ±0.15 °C
- D/A accuracy = ±0.03% of 100 °C or ±0.03 °C
- Total accuracy = ±0.18 °C.

Accuracy Example (Foundation fieldbus devices)

When using a Pt 100 ($\alpha = 0.00385$) sensor input:

- Total accuracy = ±0.15 °C.
- No D/A accuracy effects apply

Rosemount 644

Ambient Temperature Effect

TABLE 3. Ambient Temperature Effect

Sensor Options	Temperature Effects per 1.0 °C (1.8 °F) Change in Ambient Temperature ⁽¹⁾	Range	D/A Effect ⁽²⁾
2-, 3-, 4-wire RTDs			
Pt 100 ($\alpha = 0.00385$)	0.003 °C (0.0054 °F)	Entire Sensor Input Range	0.001% of span
Pt 100 ($\alpha = 0.003916$)	0.003 °C (0.0054 °F)	Entire Sensor Input Range	0.001% of span
Pt 200	0.004 °C (0.0072 °F)	Entire Sensor Input Range	0.001% of span
Pt 500	0.003 °C (0.0054 °F)	Entire Sensor Input Range	0.001% of span
Pt 1000	0.003 °C (0.0054 °F)	Entire Sensor Input Range	0.001% of span
Ni 120	0.003 °C (0.0054 °F)	Entire Sensor Input Range	0.001% of span
Cu 10	0.03 °C (0.054 °F)	Entire Sensor Input Range	0.001% of span
Thermocouples			
Type B	0.014 °C	$R \geq 1000^{\circ}\text{C}$	0.001% of span
	0.032 °C – (0.0025% of $(R - 300)$)	$300^{\circ}\text{C} \leq R < 1000^{\circ}\text{C}$	0.001% of span
	0.054 °C – (0.011% of $(R - 100)$)	$100^{\circ}\text{C} \leq R < 300^{\circ}\text{C}$	0.001% of span
Type E	0.005 °C + (0.00043% of R)	All	0.001% of span
Type J	0.0054 °C + (0.00029% of R)	$R \geq 0^{\circ}\text{C}$	0.001% of span
	0.0054 °C + (0.0025% of absolute value R)	$R < 0^{\circ}\text{C}$	0.001% of span
Type K	0.0061 °C + (0.00054% of R)	$R \geq 0^{\circ}\text{C}$	0.001% of span
	0.0061 °C + (0.0025% of absolute value R)	$R < 0^{\circ}\text{C}$	0.001% of span
Type N	0.0068 °C + (0.00036% of R)	All	0.001% of span
Type R, S, W5Re/W26Re	0.016 °C	$R \geq 200^{\circ}\text{C}$	0.001% of span
	0.023 °C – (0.0036% of R)	$R < 200^{\circ}\text{C}$	0.001% of span
Type T	0.0064 °C	$R \geq 0^{\circ}\text{C}$	0.001% of span
	0.0064 °C + (0.0043% of absolute value R)	$R < 0^{\circ}\text{C}$	0.001% of span
DIN Type L	0.0054 °C + (0.00029% of R)	$R \geq 0^{\circ}\text{C}$	0.001% of span
	0.0054 °C + (0.0025% of absolute value R)	$R < 0^{\circ}\text{C}$	0.001% of span
DIN Type U	0.0064 °C	$R \geq 0^{\circ}\text{C}$	0.001% of span
	0.0064 °C + (0.0043% of absolute value R)	$R < 0^{\circ}\text{C}$	0.001% of span
Millivolt Input	0.0005 mV	Entire Sensor Input Range	0.001% of span
2-, 3-, 4-wire Ohm	0.0084 Ω	Entire Sensor Input Range	0.001% of span

(1) Change in ambient is with reference to the calibration temperature of the transmitter 68 °F (20 °C) from factory.

(2) Does not apply to FOUNDATION Fieldbus.

Transmitters can be installed in locations where the ambient temperature is between –40 and 85 °C (–40 and 185 °F). In order to maintain excellent accuracy performance, each transmitter is individually characterized over this ambient temperature range at the factory.

Temperature Effects Example (HART devices)

When using a Pt 100 ($\alpha = 0.00385$) sensor input with a 0–100 °C span at 30 °C ambient temperature:

- Digital Temperature Effects: $0.003^{\circ}\text{C} \times (30 - 20) = 0.03^{\circ}\text{C}$
- D/A Effects: $[0.001\% \text{ of } 100] \times (30 - 20) = 0.01^{\circ}\text{C}$
- Worst Case Error: Digital + D/A + Digital Temperature Effects + D/A Effects = $0.15^{\circ}\text{C} + 0.03^{\circ}\text{C} + 0.03^{\circ}\text{C} + 0.01^{\circ}\text{C} = 0.22^{\circ}\text{C}$
- Total Probable Error: $\sqrt{0.15^2 + 0.03^2 + 0.03^2 + 0.01^2} = 0.16^{\circ}\text{C}$

Temperature Effects Examples (Foundation fieldbus devices)

When using a Pt 100 ($\alpha = 0.00385$) sensor input at 30 °C span at 30 °C ambient temperature:

- Digital Temperature Effects: $0.003^{\circ}\text{C} \times (30 - 20) = 0.03^{\circ}\text{C}$
- D/A Effects: No D/A effects apply
- Worst Case Error: Digital + Digital Temperature Effects = $0.15^{\circ}\text{C} + 0.03^{\circ}\text{C} = 0.18^{\circ}\text{C}$
- Total Probable Error: $\sqrt{0.15^2 + 0.03^2} = 0.153^{\circ}\text{C}$

Product Certifications

ROSEMOUNT 644 WITH FOUNDATION FIELDBUS

Approved Manufacturing Locations

Emerson Process Management Rosemount Division. –
Chanhassen, Minnesota, USA
Rosemount Temperature GmbH – Germany
Emerson Process Management Asia Pacific – Singapore

European Union Directive Information

The EC declaration of conformity for all applicable European directives for this product can be found on the Rosemount website at www.rosemount.com. A hard copy may be obtained by contacting our local sales representative.

ATEX Directive (94/9/EC)

Rosemount Inc. complies with the ATEX Directive.

Electro Magnetic Compatibility (EMC) (89/336/EEC)

644H and 644R – EN 50081-1: 1992; EN 50082-2:1995;
EN 61326-1:1997 +A1

Hazardous Locations Certificates

The product certifications for the Rosemount 644 with FOUNDATION fieldbus are pending. Consult the factory for additional information.

North American Certifications

Factory Mutual (FM) Approvals

I5 FM Intrinsic Safety
Intrinsically Safe (Entity) / FISCO for use in Class I, II, III, Division 1, Groups A, B, C, D, E, F, and G; when installed per control drawing 00644-2075.
Temperature Code: T4 ($T_{amb} = -50\text{ °C}$ to 60 °C).

Nonincendive for use in Class I, Division 2, Groups A, B, C, and D.

Temperature Code: T4 ($T_{amb} = -50\text{ °C}$ to 85 °C);
T5 ($T_{amb} = -50\text{ °C}$ to 70 °C)

E5 FM Explosion Proof
Explosion Proof for Class I, Division 1, Groups B, C, and D.
Dust Ignition Proof for Class II/III, Division 1, Groups E, F, G.

Canadian Standards Association (CSA) Approvals

I6 CSA Intrinsic Safety
Intrinsically Safe and FISCO for Class I, Division 1, groups A, B, C, and D when connected per Rosemount drawing 00644-2076.

Temperature code: T4 ($T_{amb} = -50\text{ °C}$ to 60 °C);

Suitable for Class I, Division 2, groups A, B, C, and D (must be installed in a suitable enclosure)

Temperature Code: T4 ($T_{amb} = -50\text{ °C}$ to 60 °C);
T5 ($T_{amb} = -50\text{ °C}$ to 85 °C)

K6 CSA Intrinsic Safety, Explosion-proof
Includes Intrinsically Safe "I6" and Explosion-Proof for Class I, Division 1, groups B, C, and D.
Dust-Ignition Proof for Class II, Division 1, Groups E, G, and G.
Dust-Ignition Proof for Class III, Division 1
Seal not required.
CSA Enclosure Type 4X

European Certifications

E1 ATEX Explosion-proof Approval
Certificate Number: KEMA99ATEX8715
ATEX Marking:  II 2 G
CE 1180
EEx d IIC T6 ($-40\text{ °C} \leq T_{amb} \leq 65\text{ °C}$)
 $U_i = 55\text{ Vdc}$

Product Data Sheet

00813-0100-4728, Rev LA

April 2006

Rosemount 644

11 ATEX Intrinsic Safety

Certificate Number: Baseefa03ATEX0499X

ATEX Marking:  II 1 G

CE 1180

EEx ia IIC T4 (-50 °C ≤ T_{amb} ≤ 60 °C)

TABLE 4. Entity Parameters

I.S. Loop/Power Terminals

U_i = 30 V

I_i = 300 mA

P_i = 1.3 W

C_i = 2.1 nF

L_i = 0

FISCO Loop/Power Terminals

U_i = 17.5 V

I_i = 380 mA

P_i = 5.32 W

C_i = 2.1 nF

L_i = 0

Sensor Terminals

U_o = 13.9 V

I_o = 23 mA

P_o = 79 mW

C_i = 7.7 nF

L_i = 0

Special Conditions for Safe Use (X):

The apparatus must be installed in an enclosure which affords it a degree of protection of at least IP20. Non-metallic enclosures must have a surface resistance of less than 1Gohm, light alloy or zirconium enclosures must be protected from impact and friction when installed.

N1 ATEX Type n

Certificate Number: BAS00ATEX3145

ATEX Marking:  II 3 G

EEx n IIC T5 (-40 °C ≤ T_{amb} ≤ +70 °C)

U_i = 45 V

NC ATEX Type n Component

Certificate Number: BAS99ATEX3084U

ATEX Marking:  II 3 G

EEx n IIC T5 (-40 °C ≤ T_{amb} ≤ 70 °C)

U_i = 45 V

ND ATEX Dust Ignition-Proof

Certificate Number: KEMA99ATEX8715

ATEX Marking:  II 1 D

T95°C (-40 °C ≤ T_{amb} ≤ +85 °C)

CE 1180

IP66

Australian Certifications

Standard Australia Quality Assurance Service (SAA)

Approvals

I7 SAA Intrinsic Safety

Certificate Number: Consult factory

Ex ia IIC

E7 SAA Explosion-Proof

Certificate Number: AUS Ex3706X

Ex d IIC T6 (T_{amb} = -40 °C to 65 °C)

N7 SAA Type n

Certificate Number: Ex 03.3877X

Ex n IIC T5 (T_{amb} = -60 °C to 75 °C);

T6 (T_{amb} = -60 °C to 50 °C)

Japanese Certifications

Japanese Industrial Standard (JIS) Approvals

I4 JIS Intrinsic Safety

E4 JIS Explosion Proof

Combination Approvals

K5 Combination of I5 and E5.

Russian GOST Certifications

PPC BA-13006:

0 Ex ia IIC T4/T5/T6

Kazakhstan GOST

Pattern approval Certificate for Measuring Instruments

See Certificate

Ukraine GOST

Pattern Approval for Measuring Instruments

See Certificate

Rosemount 644

ROSEMOUNT 644 WITH HART

Approved Manufacturing Locations

Emerson Process Management Rosemount Division. –
Chanhassen, Minnesota, USA
Rosemount Temperature GmbH – Germany
Emerson Process Management Asia Pacific – Singapore

European Union Directive Information

The EC declaration of conformity for all applicable European directives for this product can be found on the Rosemount website at www.rosemount.com. A hard copy may be obtained by contacting our local sales representative.

ATEX Directive (94/9/EC)

Rosemount Inc. complies with the ATEX Directive.

Electro Magnetic Compatibility (EMC) (89/336/EEC)

644H and 644R – EN 50081-1: 1992; EN 50082-2:1995;
EN 61326-1:1997 +A1

Hazardous Locations Certificates

North American Certifications

Factory Mutual (FM) Approvals

- I5 FM Intrinsic Safety and Non-incendive
Intrinsically Safe for Class I/II/III, Division 1, Groups A, B, C, D, E, F, and G.
Non-incendive for Class I, Division 2, Groups A, B, C, and D.
Intrinsically Safe and non-incendive when installed in accordance with Rosemount drawing 00644-0009.

TABLE 5. Temperature Code

Pi	Temperature Code
0.67 W	T5 (T _{amb} = – 50 °C to 50 °C)
0.67 W	T6 (T _{amb} = – 50 °C to 40 °C)
1.0 W	T4 (T _{amb} = – 50 °C to 80 °C)
1.0 W	T5 (T _{amb} = – 50 °C to 40 °C)

- E5 FM Explosion-Proof and Non-incendive
Explosion-Proof for Class I, Division 1, Groups B, C, and D.
Dust Ignition Proof for Class II/III, Division 1, Groups E, F, G when installed per Rosemount Drawing 00644-1049.
Non-incendive for Class 1, Division 2, Groups A, B, C, and D.
Temperature Code: T5 (T_{amb} = –50°C to 85°C)
Conduit seal not required for compliance with NEC501–5a(1).

NOTE

Approval E5 is only available with 644H option codes J5 and J6.

- K5 Combination of I5 and E5.

NOTE

K5 is only available with 644H option code J6.

Canadian Standards Association (CSA) Approvals

- I6 CSA Intrinsic Safety
Intrinsically Safe for Class I, Division 1, Groups A, B, C, and D when installed in accordance with Rosemount drawing 00644–1064.

TABLE 6. Temperature Code

Pi	Temperature Code
0.67 W	T6 (T _{amb} = – 50 °C to 40 °C)
0.67 W	T5 (T _{amb} = – 50 °C to 60 °C)
1.0 W	T4 (T _{amb} = – 50 °C to 80 °C)

- K6 CSA Intrinsic Safety, Explosion–Proof, and Non-incendive
Combination of I6 and Explosion–proof for Class I, Division 1, Groups B, C, and D; Dust-ignition proof for Class II, Division 1, Groups E, F, and G; Class III, Division 1 hazardous locations, when installed in accordance with Rosemount drawing 00644–1059.
Suitable for Class I, Division 2, Groups B, C, and D when installed in a suitable enclosure.
Temperature Code: Ambient Limits –50°C to 85°C.

NOTE

K6 is only available with 644H option code J6.

European Certifications

- I1 ATEX Intrinsic Safety
Certificate Number: BAS00ATEX1033X
ATEX Marking:  II 1 G EEx ia IIC T4/T5/T6
CE 1180

TABLE 7. Temperature Code

Pi	Temperature Code
0.67 W	T6 (– 60 °C ≤ T _{amb} ≤ 40 °C)
0.67 W	T5 (– 60 °C ≤ T _{amb} ≤ 50 °C)
1.0 W	T5 (– 60 °C ≤ T _{amb} ≤ 40 °C)
1.0 W	T4 (– 60 °C ≤ T _{amb} ≤ 80 °C)

TABLE 8. Entity Parameters

Loop/Power	Sensor
U _i = 30 V	U _o = 13.6 V
I _i = 200 mA	I _o = 80 mA
P _i = 0.67 W or 1.0 W	P _o = 80 mW
C _i = 10 nF	C _i = 75 nF
L _i = 0	L _i = 0

Special Conditions for Safe Use (X):

The transmitter must be installed so that its external terminals and communication pins are protected to at least IP20.
Non-metallic enclosures must have a surface resistance of less than 1GΩ. Light alloy or zirconium enclosures must be protected from impact and friction when installed.

- E1 ATEX Flame-Proof
Certificate Number: KEMA99ATEX8715
ATEX Marking:  II 2 G EEx d IIC T6
CE 1180
Temperature Code: T6 (–40°C ≤ T_{amb} ≤ 65°C)
Max Input Voltage: U_i=55Vdc

N1 ATEX Type n
Certificate Number: BAS00ATEX3145
ATEX Marking:  II 3 G EEx nL IIC T5
Temperature Code: T5 ($-40^{\circ}\text{C} \leq T_{\text{amb}} \leq 70^{\circ}\text{C}$)
Max Input Voltage: $U_i=45\text{Vdc}$

NC ATEX Type n Component
Certificate Number: BAS99ATEX3084U
ATEX Marking:  II 3 G EEx nL IIC T5
Temperature Code: T5 ($-40^{\circ}\text{C} \leq T_{\text{amb}} \leq 70^{\circ}\text{C}$)
Max Input Voltage: $U_i=45\text{Vdc}$

NOTE

The equipment must be installed in an enclosure meeting the requirements of IP54 and the requirements of the impact tests described in EN50021.

ND Atex Dust Ignition-Proof
ATEX Marking: II 1 D
T95 C (-40 C = Tamb = +85 C
IP 66

Australian Certifications

Standard Australia Quality Assurance Service (SAA) Approvals

E7 SAA Explosion-Proof
Certificate Number: AUS Ex3706X
Ex d IIC T6
Temperature Code: T6 ($T_{\text{amb}}=-40^{\circ}\text{C}$ to 65°C)

NOTE

Flame-Proof certification is only available as a complete assembly with Rosemount universal head – option codes J5 or J6.

I7 SAA Intrinsic Safety
Certificate Number: AUS Ex 03.3877X
Ex ia IIC
Temperature Code: T5 ($T_{\text{amb}} = -60$ to 75°C)
T6 ($T_{\text{amb}} = -60$ to 50°C)

TABLE 9. Input Entity Parameters

Loop / Power	Sensor
$U_i = 30\text{ V dc}$	$U_o = 17.3\text{ V}$
$I_i = 200\text{ mA}$	$I_o = 247\text{ mA}$
$P_i = 1.0\text{ W}$	$P_o = 0.08\text{ W}$
$C_i = 5.3\text{ nF}$	$C_o = 0.70\text{ }\mu\text{F}$
$L_i = 0\text{ mH}$	$L_o = 3.13\text{ mH}$

Special Conditions for Safe Use (X):

- It is a condition of safe use that for Ex ia applications, the equipment is to be housed in an enclosure that provides an ingress protection rating of not less than IP20.
- It is a condition of safe use that the installation shall be carried out in according with Rosemount drawing 00644-1044.
- It is a condition of safe use that a user may fit an optional LCD indicator to 644H Temperature Transmitter certified in this certificate after installation subject to the conditions requirement of this certificate.

N7 SAA Type n
Certificate Number: AUS Ex 03.3877X
Ex n IIC
Temperature Code: T5 ($T_{\text{amb}} = -60$ to 75°C)
T6 ($T_{\text{amb}} = -60$ to 50°C)

Special Conditions for Safe Use (X):

- It is a condition of safe use that for Ex n applications, the equipment is to be housed in an enclosure that provides an ingress protection rating of not less than IP54.
- Input parameters for non-sparking protection model: Ex n Input Parameters Power/Loop Terminals (Pins "+", "-", "T"); Maximum Input Voltage $U_n = 55\text{ V}$
Maximum Input Power $P_n = 1.3\text{ W}$

Brazilian Certifications

Centro de Pesquisas de Energia Eletrica (CEPEL) Approval

I2 CEPEL Intrinsic Safety. Not available, consult factory

Russian Certifications

Gostandart

Tested and approved by the Russian Metrological Institute GOSTANDART.

Japanese Certifications

Japanese Industrial Standard (JIS) Approvals

E4 JIS Explosion-Proof

TABLE 10. Certificate and Description

Certificate	Description	Approval Group	Temp Code
C15744	644H with meter and no sensor	Ex d II C	T6
C15745	644H without meter and no sensor	Ex d II C	T6
C15749	644H without meter and with RTD	Ex d II B	T4
C15750	644H without meter and with thermocouple	Ex d II B	T4
C15751	644H with meter and thermocouple	Ex d II B	T4
C15752	644H with meter and RTD	Ex d II B	T4
C15910	644H without meter and with thermocouple	Ex d II B + H2	T4
C15911	644H with meter and thermocouple	Ex d II B + H2	T4
C15912	644H without meter and with RTD	Ex d II B + H2	T4
C15913	644H with meter and RTD	Ex d II B + H2	T4

Slovak Republic Certification

EEx ia IIC T4 & T5
See Intrinsic Safety Certificate

**HART
4-20 mA**

Dimensional Drawings

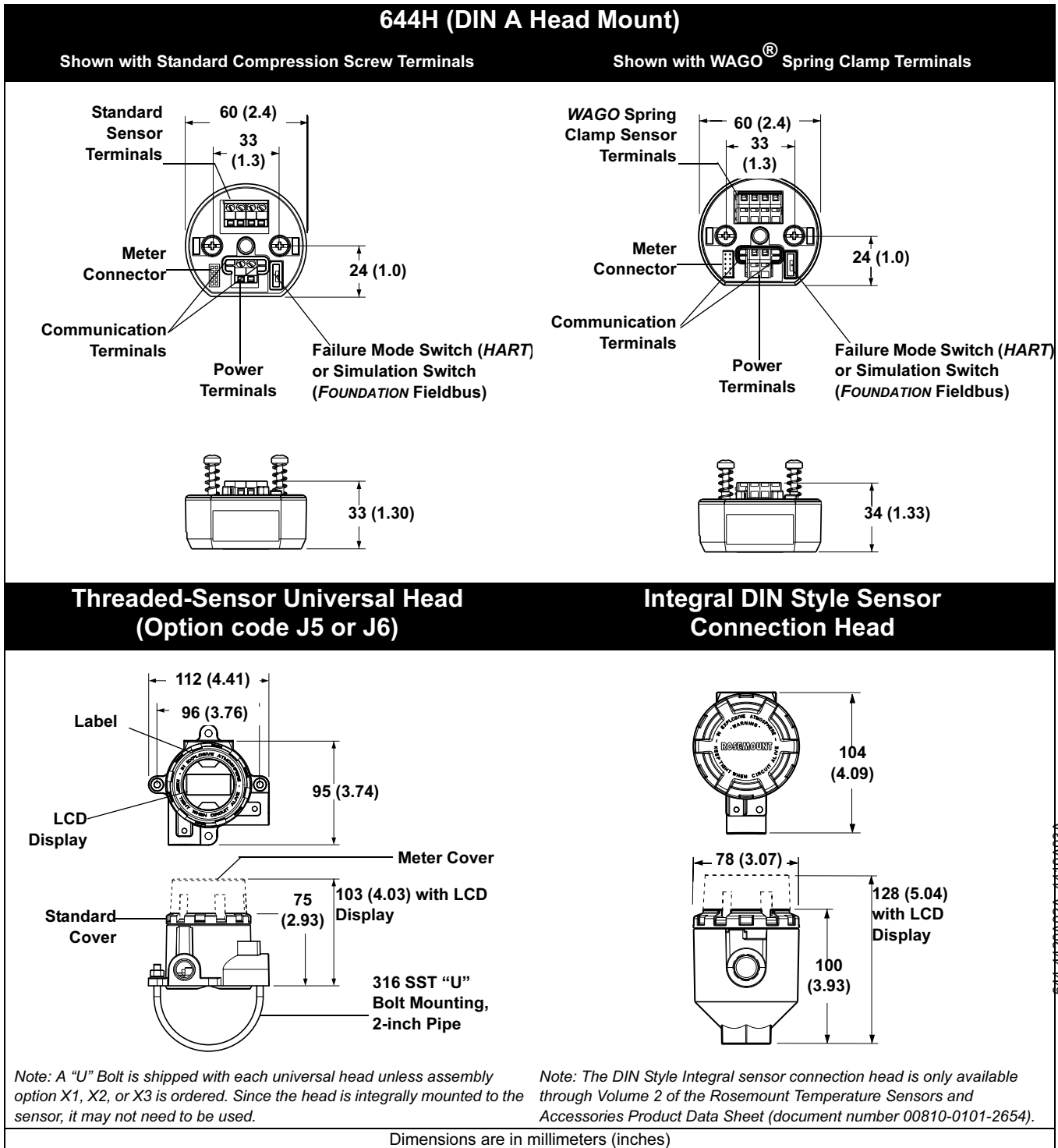

644-4#20A02A, 4#10A03A

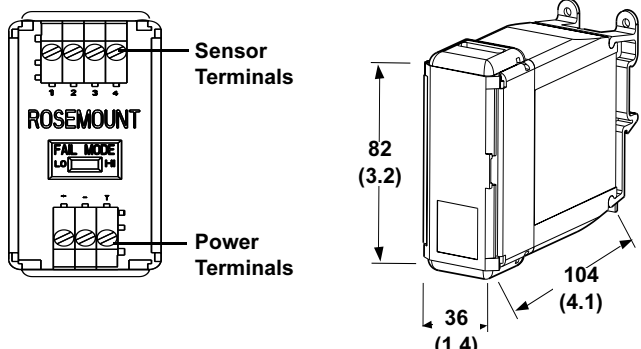
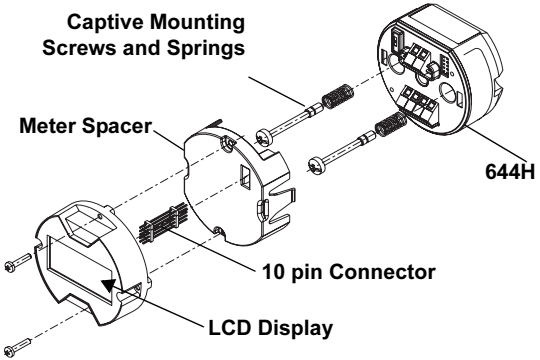
644 Rail Mount <i>HART Protocol Only</i>	LCD Display Head Mount Transmitter
 <p>Sensor Terminals</p> <p>ROSEMOUNT</p> <p>Power Terminals</p> <p>82 (3.2)</p> <p>104 (4.1)</p> <p>36 (1.4)</p>	 <p>Captive Mounting Screws and Springs</p> <p>Meter Spacer</p> <p>644H</p> <p>10 pin Connector</p> <p>LCD Display</p>

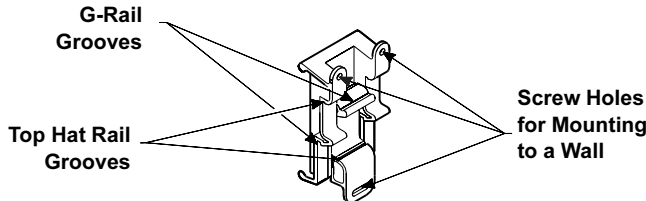
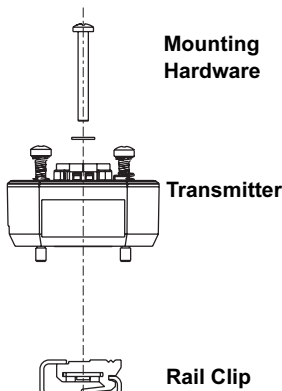
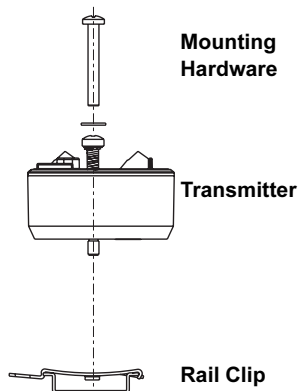
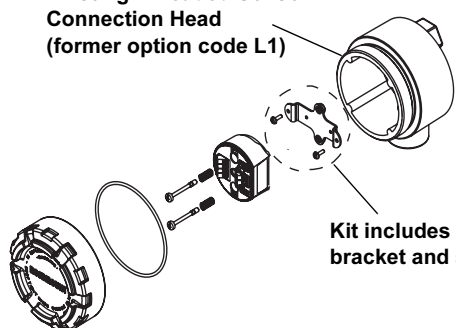
Mounting		
Universal Clip for Mounting to a Wall or a Rail (part number 03044-4103-0001)	Head Mount G-Rail (asymmetric)	Top Hat Rail (symmetric)
 <p>G-Rail Grooves</p> <p>Top Hat Rail Grooves</p> <p>Screw Holes for Mounting to a Wall</p>	 <p>Mounting Hardware</p> <p>Transmitter</p> <p>Rail Clip</p>	 <p>Mounting Hardware</p> <p>Transmitter</p> <p>Rail Clip</p>
<p><i>Note: Kit (part number 00644-5301-0010) includes mounting hardware and both types of rail kits.</i></p>		
644H Retrofit Kit		
 <p>Existing Threaded Sensor Connection Head (former option code L1)</p> <p>Kit includes replacement bracket and screws.</p>		
<p><i>Note: Kit (part number 00644-5321-0010) includes a new mounting bracket and the hardware necessary to facilitate the installation.</i></p>		

3044-4001A01B, 644-5302B01A, D02A
 3044-0000C01B, D01B, 644-1041B02B, G02

Ordering Information

● = Available
– = Not Available

Model	Product Description				
644	Smart Temperature Transmitter				
Code	Transmitter Type				
H	Head Mount (suitable for mounting in the field with enclosure options below)				
R	Rail Mount				
Code	Output	Head		Rail	
A	4–20 mA with digital signal based on HART protocol	●		●	
F	Foundation fieldbus digital signal (includes 2 AI function blocks and Backup Link Active Scheduler)	●			–
Code	Product Certifications	A	F	A	F
Hazardous Locations Certificates (consult factory for availability)					
NA	No approval	●	●	●	–
E5	FM Explosion–Proof	●	●	–	–
I5 ⁽¹⁾	FM Intrinsic Safety (includes standard I.S. and FISCO for Fieldbus units)	●	●	●	–
K5 ⁽¹⁾	FM Intrinsic Safety and Explosion–Proof combination (includes standard I.S. and FISCO for Fieldbus units)	●	●	–	–
I6 ⁽¹⁾	CSA Intrinsic Safety (includes standard I.S. and FISCO for Fieldbus units)	●	●	●	–
K6 ⁽¹⁾	CSA Intrinsic Safety and Explosion–Proof combination (includes standard I.S. and FISCO for Fieldbus units)	●	●	–	–
E1	ATEX Flame–Proof	●	●	–	–
N1	ATEX Type n	●	●	–	–
NC	ATEX Type n Component	●	●	●	–
ND	ATEX Dust Ignition–Proof	●	●	–	–
I1 ⁽¹⁾	ATEX Intrinsic Safety (includes standard I.S. and FISCO for Fieldbus units)	●	●	●	–
E7	SAA Flame–Proof	●	●	–	–
I7 ⁽²⁾⁽¹⁾	SAA Intrinsic Safety (includes standard I.S. and FISCO for Fieldbus units)	●	●	●	–
N7 ⁽²⁾	SAA Type n	●	●	–	–
I2 ⁽²⁾	CEPEL Intrinsic Safety	●	●	–	–
E4 ⁽²⁾	JIS Explosion–Proof	●	●	–	–
I4 ⁽²⁾	JIS Intrinsic Safety	●	●	●	–
Code	Options	A	F	A	F
Plant Web Software Functionality					
A01	Regulatory Control Suite – 1 PID Block	–	●	–	–
Assembly					
XA	Sensor specified separately and assembled to transmitter	●	●	–	–
Local Display (644H only)					
M5	LCD Display	●	●	–	–
Enclosure					
J5 ⁽³⁾	Universal Head (junction box), aluminum alloy with 50.8 mm (2-in.) 316 SST pipe bracket (M20 entries)	●	●	–	–
J6 ⁽³⁾	Universal Head (junction box), aluminum alloy with 50.8 mm (2-in.) 316 SST pipe bracket (1/2–14 NPT entries)	●	●	–	–
J7 ⁽³⁾	Universal Head (junction box), cast SST with 50.8 mm (2-in.) 316 SST pipe bracket (M20 entries)	●	●	–	–
J8 ⁽³⁾	Universal Head (junction box), cast SST with 50.8 mm (2-in.) 316 SST pipe bracket (1/2–14 NPT entries)	●	●	–	–
S1	Connection Head, Polished Stainless Steel (1/2–14 NPT entries)	●	●	–	–
S2	Connection Head, Polished Stainless Steel (1/2–14 NPSM entries)	●	●	–	–
S3	Connection Head, Polished Stainless Steel (M20 x 1.5 conduit and entries)	●	●	–	–
S4	Connection Head, Polished Stainless Steel (M20 x 1.5 conduit entries, M24 x 1.5 head entry)	●	●	–	–
Configuration Options					
C1	Factory configuration date, descriptor, and message fields (“Configuration Data Sheet” on page 21 required).	●	●	●	–
C2	Transmitter-sensor matching, trim to specific Rosemount RTD calibration schedule (CVD constants)	●	●	●	–
A1	Analog output levels compliant with NAMUR-recommendations NE 43: June 1997: high alarm configuration	●	–	●	–
CN	Analog output levels compliant with NAMUR-recommendations NE 43: June 1997: low alarm configuration	●	–	●	–
C8	Low Alarm (standard Rosemount alarm and saturation values)	●	–	●	–
F6	60 Hz line voltage filter	●	●	●	–

● = Available
 – = Not Available

		Head		Rail	
		A	F	A	F
Calibration Option					
C4	5-point calibration. Use option code Q4 to generate a calibration certificate	●	●	●	–
Q4	Calibration certificate. 3-Point calibration with certificate	●	●	●	–
Accessory Options					
G1	External ground lug assembly ⁽⁴⁾ (see “External Ground Screw Assembly” on page 18)	●	●	–	–
G2	Cable gland ⁽⁵⁾	●	●	–	–
G3	Cover chain. Only available with enclosure option codes J5 or J6. Not available with LCD Display option code M5.	●	●	–	–
G5	WAGO spring clamp terminals	●	●	–	–
Conduit Electrical Connector					
GE ⁽⁶⁾	M12, 4-pin, Male Connector (eurofast [®])	●	●	–	–
GM ⁽⁶⁾	A size Mini, 4-pin, Male Connector (minifast [®])	●	●	–	–

Typical Rail Mount Model Number: 644 R A I5
Typical Head Mount Model Number: 644 H F I5 A01

- (1) When IS approval is ordered on a Foundation fieldbus, both standard IS and FISCO IS approvals apply. The device label is marked appropriately.
- (2) Consult factory for availability.
- (3) Suitable for remote mount configuration.
- (4) Only available with Enclosure option code J5 or J6. For ATEX approved units the Ground Lug Assembly is included. It is not necessary to include code G1 for units with ATEX approvals.
- (5) Only available with Enclosure option code J5.
- (6) Available with Intrinsically Safe approvals only. For FM Intrinsically Safe or non-incendive approval (option code I5), install in accordance with Rosemount drawing 03151-1009 to maintain NEMA 4X rating.

NOTE

For additional options (e.g. “K” codes), please contact your local Emerson Process Management representative.

Rosemount 644

Tagging

Hardware

- No charge
- 2 lines of 28 characters (56 characters total)
- Tags are adhesive labels
- Permanently attached to transmitter
- Character height is 1/16-in (1.6 mm)

Software

- No charge
- The transmitter can store up to 30 characters for *Foundation* Fieldbus or 8 for *HART* protocol. If no characters are specified, the first 8 characters of the hardware tag are the default.

Considerations

Special Mounting Considerations

See "Mounting" on page 15 for the special hardware that is available to:

- Mount a 644H to a DIN rail. (see Table 11 on page 18)
- Retrofit a new 644H to replace an existing 644H transmitter in an existing threaded sensor connection head.(see Table 11 on page 18)

External Ground Screw Assembly

Specifying option code G1 to order the external ground screw assembly. It is not necessary to order option code G1 for those approvals that include the ground screw assembly, The table below identifies which approval options include the external ground screw assembly.

Approval Type	External Ground Screw Assembly Included?
E5, K5, I5, I6, K6, NC, NA	No—Order option code G1
N1, E1, ND, I1, E7, N7, I7, I4, and E4	Yes

TABLE 11. Transmitter Accessories

Part Description	Part Number
Aluminum alloy Universal Head, standard cover—M20 entries	00644-4420-0002
Aluminum alloy Universal Head, meter cover—M20 entries	00644-4420-0102
Aluminum alloy Universal Head, standard cover—1/2-14 NPT entries	00644-4420-0001
Aluminum alloy Universal Head, meter cover—1/2-14 NPT entries	00644-4420-0101
LCD Display (includes meter and meter spacer assembly)	00644-4430-0002
LCD Display kit (includes meter and meter spacer assembly, and meter cover)	00644-4430-0001
Ground screw assembly kit	00644-4431-0001
Kit, Hardware for mounting a 644H to a DIN rail (includes clips for symmetrical and asymmetrical rails)	00644-5301-0010
Kit, Hardware for retrofitting a 644H in an existing threaded sensor connection head (former option code L1)	00644-5321-0010
Kit, 316 U-Bolt for Universal Housing	00644-4423-0001
Universal clip for rail or wall mount	03044-4103-0001
24 Inches of symmetric (top hat) rail	03044-4200-0001
24 Inches of asymmetric (G) Rail	03044-4201-0001
Ground clamp for symmetric or asymmetric rail	03044-4202-0001
End clamp for symmetric or asymmetric rail	03044-4203-0001
Snap rings kit (used for assembly to a DIN sensor – quantity 12)	00644-4432-0001
SST Universal Head, standard cover—M20 entries	00644-4433-0002
SST Universal Head, meter cover—M20 entries	00644-4433-0102
SST Universal Head, standard cover—1/2-14 NPT entries	00644-4433-0001
SST Universal Head, meter cover—1/2-14 NPT entries	00644-4433-0101
Polished SST Connection Head, standard cover—1/2-14 NPT entries	00079-0312-0011
Polished SST Connection Head, meter cover—1/2-14 NPT entries	00079-0312-0111
Polished SST Connection Head, standard cover—1/2-14 NPSM entries	00079-0312-0022
Polished SST Connection Head, meter cover—1/2-14 NPSM entries	00079-0312-0122
Polished SST Connection Head, standard cover—M20 x 1.5 entries	00079-0312-0033
Polished SST Connection Head, meter cover—M20 x 1.5 entries	00079-0312-0133
Polished SST Connection Head, standard cover—M20 x 1.5 / M24 x 1.5 entries	00079-0312-0034
Polished SST Connection Head, meter cover—M20 x 1.5 / M24 x 1.5 entries	00079-0312-0134

Configuration

Transmitter Configuration

The transmitter is available with standard configuration setting for either *HART* (see Standard HART Configuration) or *FOUNDATION* fieldbus (see Standard Foundation Fieldbus Configuration). The configuration settings and block configuration may be changed in the field with the Fisher-Rosemount Systems DeltaV[®], with *AMSinside*, or other *FOUNDATION* fieldbus host or configuration tool.

Custom Configuration

Custom configurations are to be specified when ordering. The following table lists the necessary requirements to specify a custom configuration.

Option Code	Requirements/ Specification
C1: Factory Configuration Data	Date: day/month/year Descriptor: 16 alphanumeric characters Message: 32 alphanumeric character (CDS required)
C2: Transmitter – Sensor Matching	The transmitters are designed to accept Callendar-Van Dusen constants from a calibrated RTD. Using these constants, the transmitter generates a custom curve to match the sensor-specific curve. Specify a Series 65, 65, or 78 RTD sensor on the order with a special characterization curve (V or X8Q4 option). These constants will be programmed into the transmitter with this option
HART only	A1: NAMUR-Compliant, High Alarm
	CN: NAMUR-Compliant, Low Alarm
C4: Five Point Calibration	Will include 5-point calibration at 0, 25, 50, 75, and 100% analog and digital output points. Use with Calibration Certificate Q4.
F6: 60 Hz Line Filter	Calibrated to a 60 Hz line voltage filter instead of 50 Hz filter

Standard HART Configuration

Unless specified, the transmitter will be shipped as follows:

Sensor Type	RTD, Pt 100 ($\alpha=0.00385$, 4-wire)
4 mA Value	0 °C
20 mA Value	100 °C
Damping	5 seconds
Output	Linear with temperature
Alarm	High (21.75 mA)
Saturation Levels	3.9 / 20.5 mA
LCD (when installed)	Engineering Units and mA
Line Voltage Filter	50 Hz
Tag	See "Tagging" on page 18

Standard FOUNDATION Fieldbus Configuration

Unless otherwise specified, the transmitter will be shipped as follows:

Sensor Type:	RTD, Pt 100 ($\alpha=0.00385$, 4-wire)
Damping:	5 seconds
Units of Measurement:	°C
Line Voltage Filter:	50 Hz
Software Tag:	See Tagging
Function Blocks Tags:	<ul style="list-style-type: none"> Resource Block: Resource Transducer Block: Transducer LCD Block: Display Analog Input Blocks: AI1, AI2
Alarm Limits of AI1 and AI2:	<ul style="list-style-type: none"> HI-HI: Infinity HI: Infinity LO: Infinity LO-LO: Infinity
Local Display (when installed):	Engineering Units of Temperature

Standard Block Configuration

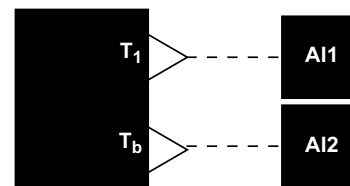

Note:
 T_1 = Sensor Temperature
 T_b = Terminal Temperature

Final Station

AI Blocks are scheduled for 1 second. AI Blocks are linked as shown above.

STAINLESS STEEL HOUSING FOR BIOTECHNOLOGY, PHARMACEUTICAL INDUSTRIES, AND SANITARY APPLICATIONS

Weight

Option Code	Standard Cover	Meter Cover
S1	840 g (27 oz)	995 g (32 oz)
S2	840 g (27 oz)	995 g (32 oz)
S3	840 g (27 oz)	995 g (32 oz)
S4	840 g (27 oz)	995 g (32 oz)

Enclosure Rating

NEMA 4X, IP66, and IP68

Materials of Construction

Housing and Standard Meter Cover

- 316L SST

Cover O-Ring

- Buna-N

LCD Display Cover

- 316L SST

- Glass

Surface

Surface finish is polished to 32 RMA. Laser etched product marking on housing and standard covers.

Dimensional Drawings

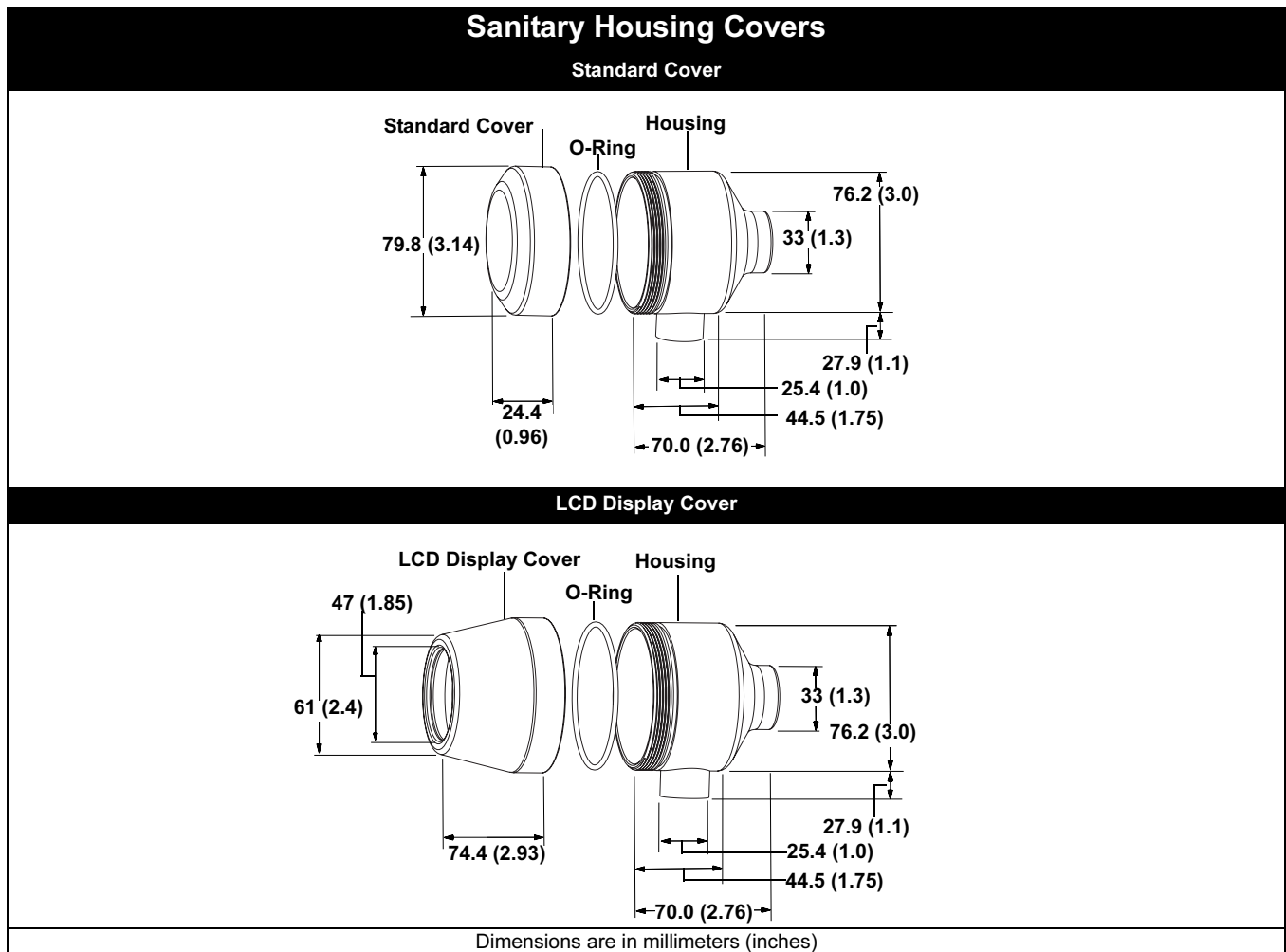

Configuration Data Sheet

HART TRANSMITTER

Customer Information

Customer	Model No.
P.O. Number	Line Item

Input-Output Information (software selectable)

Sensor Type <input type="checkbox"/> Pt 100 $\alpha = 0.00385$ ★ <input type="checkbox"/> Pt 100 $\alpha = 0.003916$ <input type="checkbox"/> Pt 200 $\alpha = 0.00385$ <input type="checkbox"/> Pt 500 $\alpha = 0.00385$ <input type="checkbox"/> Pt 1000 $\alpha = 0.00385$ <input type="checkbox"/> Cu 10 <input type="checkbox"/> Ni 120 <input type="checkbox"/> Transmitter Sensor matching (C2 Option)	No. of Leads <input type="checkbox"/> 2-Wire <input type="checkbox"/> 3-Wire <input type="checkbox"/> 4-Wire ★	<input type="checkbox"/> NIST Type B T/C <input type="checkbox"/> NIST Type E T/C <input type="checkbox"/> NIST Type J T/C <input type="checkbox"/> NIST Type K T/C <input type="checkbox"/> NIST Type N T/C <input type="checkbox"/> NIST Type R T/C <input type="checkbox"/> Type W5Re/W26Re <input type="checkbox"/> NIST Type S T/C	<input type="checkbox"/> NIST Type T T/C <input type="checkbox"/> DIN Type L T/C <input type="checkbox"/> DIN Type U T/C <input type="checkbox"/> mV <input type="checkbox"/> Ohms
4-20 mA Points and Damping 4 mA Value <input type="checkbox"/> 0 °C ★ <input type="checkbox"/> _____ °C <input type="checkbox"/> _____ °F <input type="checkbox"/> _____ °R <input type="checkbox"/> _____ K <input type="checkbox"/> _____ mV <input type="checkbox"/> _____ Ohms	20 mA Value <input type="checkbox"/> 100 °C ★ <input type="checkbox"/> _____ °C <input type="checkbox"/> _____ °F <input type="checkbox"/> _____ °R <input type="checkbox"/> _____ K <input type="checkbox"/> _____ mV <input type="checkbox"/> _____ Ohms	Damping <input type="checkbox"/> 5 Seconds ★ <input type="checkbox"/> Other _____ (Value must be less than 32 seconds)	

Tagging

Hardware Tag _____ (13 characters maximum)
 Software Tag _____ (8 characters maximum - default is first 8 characters of the hardware tag)

Transmitter Information

Integral Meter With Meter (choose as many as desired)
 (644H Only-M5 option) **Engineering Units** ★ **mA** ★
 Percent Range
 NOTE: If an integral meter is ordered with the transmitter, the default configuration alternates between "Engineering Units" and "mA."
Descriptor (C1 Option) _____ (16 characters maximum)
Message (C1 Option) _____
 _____ (2 Lines x 16 characters max)
Date (C1 Option) Day ____ (numeric) ____ Month (alphabetic) ____ Year (numeric)

Failure Mode and Software Security

Failure Mode **High** ★ Low
 Software Security **Off** ★ On

Signal Selection

4-20 mA with simultaneous digital signal based on HART protocol ★
 Burst mode of HART digital process variable
 Burst mode output options:
 Primary variable in engineering units Primary variable in percent of range Multidrop Communication
 NOTE: This option fixes the transmitter's analog output at 4 mA. Choose a transmitter address for each transmitter (1 - 15) _____
 NOTE: Default transmitter address is "1" if multidrop communications is selected

Alarm and Saturation Values

Rosemount Standard ★
 NAMUR-compliant. Available with option code A1 or CN.
 Custom
 High Alarm Level: _____ mA (must be between 21.0 and 23.0 mA)
 Low Alarm Level: _____ mA (must be between 3.5 and 3.75 mA)
 High Saturation Level: _____ mA (must be between 20.5 mA and the High Alarm Value minus 0.1 mA)
 Low Saturation Level: _____ mA (must be between the Low Alarm Value plus 0.1 mA and 3.9 mA)

★ = Standard Configuration

 HART
 4-20 mA

Rosemount 644

Configuration Data Sheet

FOUNDATION™ Fieldbus transmitter

★ = Default Configuration

Customer Information

Customer _____ Model No. _____
 P.O. No. _____ Line Item _____

Transmitter Tagging

Hardware Tag _____

 (2 lines x 28 character max.)

Physical Device Tag _____
 (32 character max.)

Integral Meter (Choose 4)

- Sensor 1 Engineering Units Sensor 2 Engineering Units Terminal Temperature
 Average Temperature Differential Temperature

Transmitter Information

Descriptor _____
 (C1 Option) (32 characters maximum)

Message _____
 (C1 Option) (48 characters maximum)

Date Day ____ Month ____ Year ____
 (C1 Option) Hour ____ Minute ____ Second ____

Security

Write Protect (software) Off ★ On

Damping

- 5 Seconds ★ Other _____ (values must be less than 32 seconds)

LCD Display

- Sensor 1 ★ Terminal Temperature

*Rosemount and the Rosemount logotype are registered trademarks of Rosemount Inc.
FOUNDATION is a trademark of the Fieldbus Foundation.
HART is a registered trademark of the HART Communication Foundation.
Eurofast and Minifast are registered trademarks of Turck Inc.
The 3-A symbol is a registered trademark of the 3-A Sanitary Standards Symbol Council.
Noryl is a registered trademark of General Electric.
Lexan is a registered trademark of General Electric.
Teflon is a registered trademark of E.I. du Pont de Nemours & Co.
All other marks are the property of their respective owners.*



SERV' INSTRUMENTATION

Mesure et Contrôle vos fluides

ZI Broteau Nord

69540 Irigny

TEL 33 (0)4 78 51 47 50

FAX 33 (0)4 78 51 59 96

<http://www.servinstrumentation.fr>

