



Sho-Rate™ 1350G & 1355G Series

Sho-Rate™ Models 1350G & 1355G

Variable Area

Low Flow Glass Tube Flowmeters

Overview

The Brooks® Sho-Rate™ Series glass tube variable area flow meter has been the industry standard glass tube variable area meter for decades. This glass tube meter is ideal for a variety of gas and liquid applications. These meters are particularly suited for purge applications. The base configuration uses a borosilicate glass tube installed in an aluminum frame with 316SS end blocks, adaptors, and valve. Additional material options, valve options, and flow controllers are available to provide the appropriate configuration for a wide variety of applications.

Product Features

- Standard direct read scales on tube for all fluids and fluid conditions (user selected)
- Standard millimeter scales with flow curves for all fluids and fluid conditions (user selected)
- Scale length (approximate) 65mm, 150mm
- Magnifier built into front shield
- Flowmeter options:
 - Multiple fitting adapters for all world areas
 - No valve, cartridge valve and precision control valve
 - Inlet & outlet valves
 - Integral flow controller, upstream & downstream
 - Multiple connection fittings to fit all applications
 - Multiple approval certifications for world wide usage

Features and Benefits

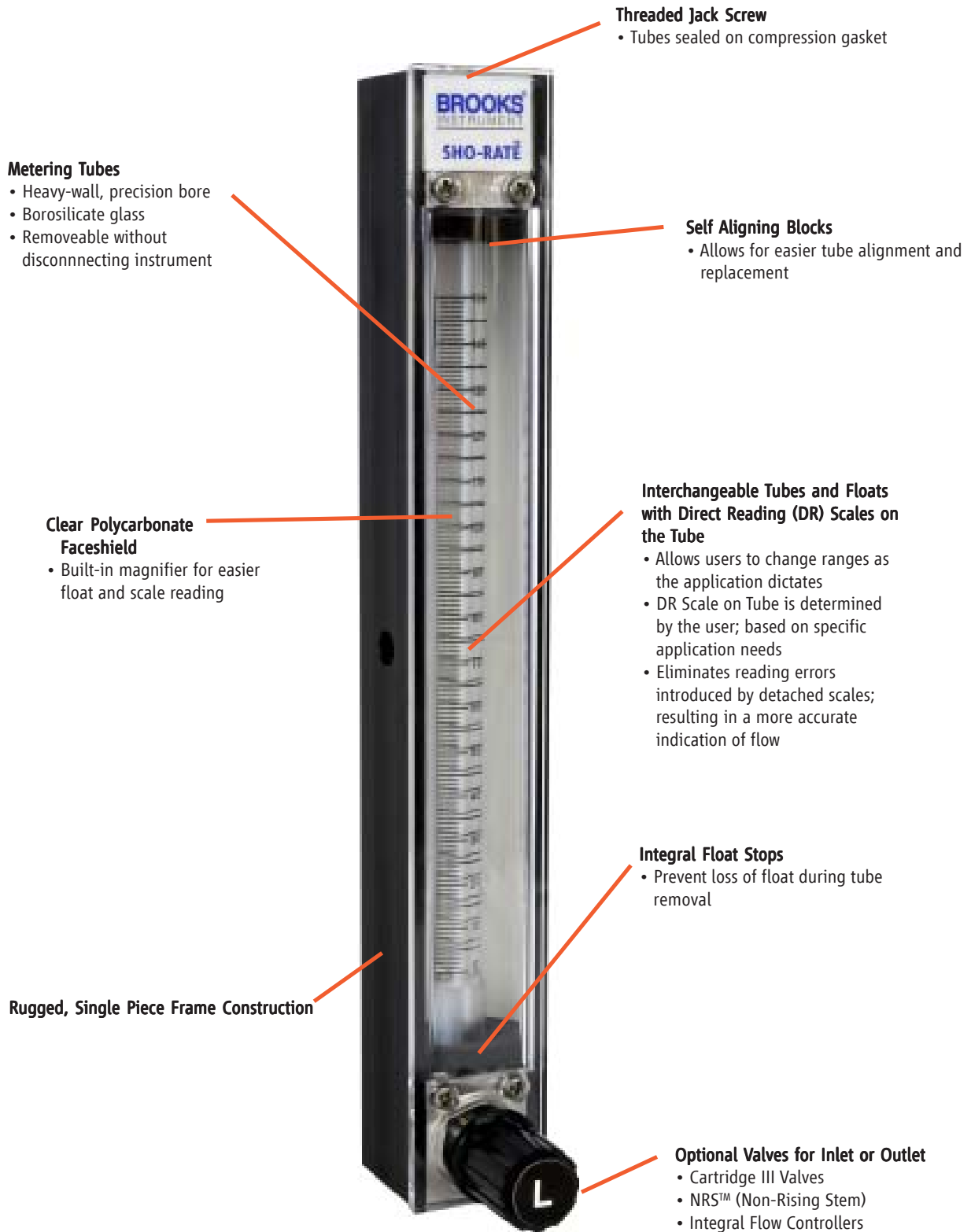

Product Specifications

Performance	1350G	1355G
Accuracy	±5% at reference conditions	± 3% at reference conditions
Repeatability	0.25% F.S.	
Pressure/Temperature	200 psig (33°F - 250°F) / 13.8 bar (1°C-121°C)	
Materials of Construction	Borosilicate glass, Brass, Aluminum, 316 Stainless Steel, Clear Polycarbonate, Milk White Polycarbonate, Teflon®	
End Block Options	Stainless Steel and Brass	
Packing Material	Viton® fluoroelastomers, Teflon®, Buna, Kalrez® perfluoroelastomers	
Float Materials	Glass, Sapphire, Stainless Steel, Carboloy®, Tantalum	
Connection Materials	Stainless Steel	
Connection Options	1/8" NPT (w/wo locknuts)	
	1/4" NPT (w/wo locknuts)	
	1/8" Compression (w/wo locknuts)	
	1/4" Compression (w/wo locknuts)	
	6 mm Compression (w/wo locknuts)	
	1/4" RC (w/wo locknuts)	
	3/8" RC (w/wo locknuts)	
	1/4" VCR®	
	1/4" ID Hose	
Swagelok® Converters		
Dimensions	See Dimension Drawings	
Alarm Availability	(coming soon)	
Valve Options	Cartridge III Valve and NRS™	
Valve Materials	Stainless Steel	
Flow Controller	Yes	
Certifications	International Calibration Certificate (ICC)	
	CRN (coming soon)	
	Pressure Equipment Directive (97/23/EC)	
	RoHS (II)	
	REACH (coming soon)	

Product Specifications - Capacities; 1350G, Rib Guided, Spherical Floats

Capacities - Rib Guide Tubes, Spherical Floats for use with 1350G Series Only						
Meter Size	Tube No.	Float Material	Water		Air	
			GPH	LPH	SCFH	NLPH
2	R-2-65-A G	Glass	0.010	0.041	0.12	3.2
		Sapphire	0.021	0.079	0.19	5.0
		Stainless Steel	0.049	0.18	0.37	9.8
		Carboloy	0.10	0.36	0.65	17
		Tantalum	0.10	0.40	0.71	18
	R-2-65-B G	Glass	0.014	0.06	0.16	4.4
		Sapphire	0.028	0.10	0.25	6.7
		Stainless Steel	0.07	0.25	0.48	12
		Carboloy	0.12	0.48	0.80	21
		Tantalum	0.14	0.53	0.87	22
	R-2-65-C G	Glass	0.12	0.47	0.99	26
		Sapphire	0.22	0.83	1.3	35
		Stainless Steel	0.41	1.5	2.1	55
		Carboloy	0.65	2.4	3.1	81
		Tantalum	0.70	2.6	3.3	87
	R-2-65-D G	Glass	0.68	2.5	3.9	100
		Sapphire	0.99	3.7	5.1	130
		Stainless Steel	1.6	6.3	7.9	200
		Carboloy	2.5	9.5	11	290
		Tantalum	2.7	10.0	12	310
6	R-6-65-A G	Glass	2.4	9.2	14	370
		Sapphire	3.6	13	18	480
		Stainless Steel	6.0	22	27	710
		Carboloy	8.9	33	38	1000
		Tantalum	9.5	36	41	1000
	R-6-65-B G	Glass	9.9	37	52	1300
		Sapphire	14.0	53	67	1700
		Stainless Steel	22.0	85	97	2500
		Carboloy	32.0	120	130	3500
		Tantalum	34.0	130	140	3700

Air flows are at 14.7 psia and 70 Degrees F/1.01 Bar and 21.1 Degrees C

Models 1350G/1355G Tube and Float Code; Decade Scale Option, 7th, 8th & 9th Digits

Seventh Digit in Model Code, for Scale Configuration		
Code	Model 1350 Tube	Model 1355 Tube
A		R-2-15-A G
B		R-2-15-B G
C		R-2-15-C G
D		R-2-15-D G
F		R-6-15-B G
G	R-2-65-A G	R-2-15-AAAA G
H	R-2-65-B G	
J	R-2-65-C G	
K	R-2-65-D G	
L	R-6-65-A G	
M	R-6-65-B G	
N	No Tube	No Tube

Eighth and Ninth Digit in Model Code, for Scale Configuration					
Meter Accuracy	Float Material	Decal Scale Inscription			
		MM Scale	Linear Scale	Custom Decal	Percent Scale
Standard (1350-10%) (1355-5%)	Glass	1A	2A	3A	4A
	Stainless Steel	1B	2B	3B	4B
	Sapphire	1C	2C	3C	4C
	Carboloy	1D	2D	3D	4D
	Tantalum	1E	2E	3E	4E
Calibrated (1350-5%) (1355-2%)	Glass	1G	2G	3G	4G
	Stainless Steel	1H	2H	3H	4H
	Sapphire	1J	2J	3J	4J
	Carboloy	1K	2K	3K	4K
	Tantalum	1L	2L	3L	4L

*Note: Code for No Float/No Scale = "ZZ"

Product Specifications - Capacities; 1355G, Rib Guided, Spherical Floats

Capacities - Rib Guide Tubes, Spherical Floats for use with 1355G Series Only				
Meter Size	Tube No.	Float Material	Maximum Flow Rate*	
			Water (CC/Min)	Air
2	R-2-15-AAAA	Glass	0.59	50 SCC/M
		Sapphire	1.1	79 SCC/M
		Stainless Steel	2.6	150 SCC/M
		Carboloy	5.2	280 SCC/M
		Tantalum	5.8	310 SCC/M
	R-2-15-D	Glass	5.5	370 SCC/M
		Sapphire	10	520 SCC/M
		Stainless Steel	20	830 SCC/M
		Carboloy	34	1200 SCC/M
		Tantalum	36	1300 SCC/M
	R-2-15-A	Glass	17	0.82 SLPM
		Sapphire	26	1.0 SLPM
		Stainless Steel	46	1.6 SLPM
		Carboloy	70	2.4 SLPM
		Tantalum	75	2.5 SLPM
	R-2-15-B	Glass	53	2.3 SLPM
		Sapphire	80	3.0 SLPM
		Stainless Steel	130	4.6 SLPM
		Carboloy	200	6.7 SLPM
		Tantalum	210	7.1 SLPM
R-2-15-C	Glass	90	4.0 SLPM	
	Sapphire	130	5.2 SLPM	
	Stainless Steel	220	7.9 SLPM	
	Carboloy	340	11 SLPM	
	Tantalum	360	11 SLPM	
6	R-6-15-A	Glass	210	9.5 SLPM
		Sapphire	320	12 SLPM
		Stainless Steel	540	18 SLPM
		Carboloy	790	25 SLPM
		Tantalum	840	26 SLPM
	R-6-15-B	Glass	560	23 SLPM
		Sapphire	820	29 SLPM
		Stainless Steel	1300	43 SLPM
		Carboloy	1900	60 SLPM
		Tantalum	2000	63 SLPM

Air flows are at 14.7 psia and 70 Degrees F/1.01 Bar and 21.1 Degrees C

Product Dimensions - Model 1350G and 1355G

Model 1350G

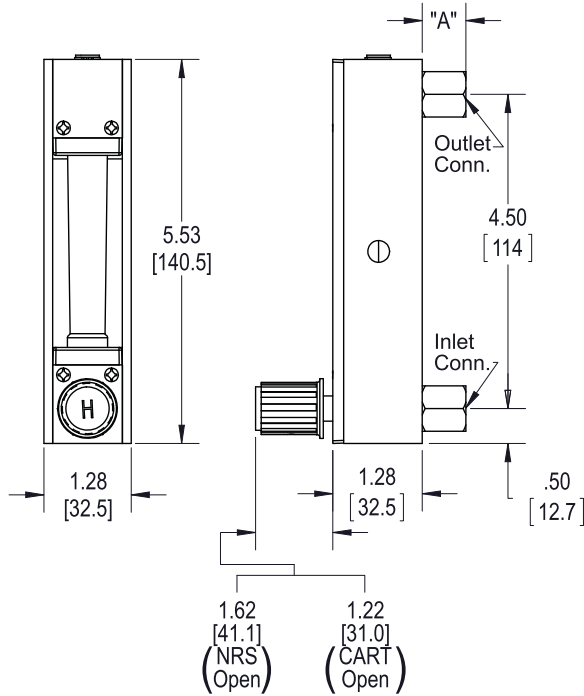

Dimension "A" Connection Adapter	
1/8" NPT	.625 [15.9]
1/4" NPT	.625 [15.9]
1/8" Compression	1.59 [40.3]
1/4" Compression	1.78 [45.1]
1/4" ID Hose	.72 [18.3]
1/4" Rc	.895 [22.7]
3/8" Rc	.895 [22.7]

Model 1355G

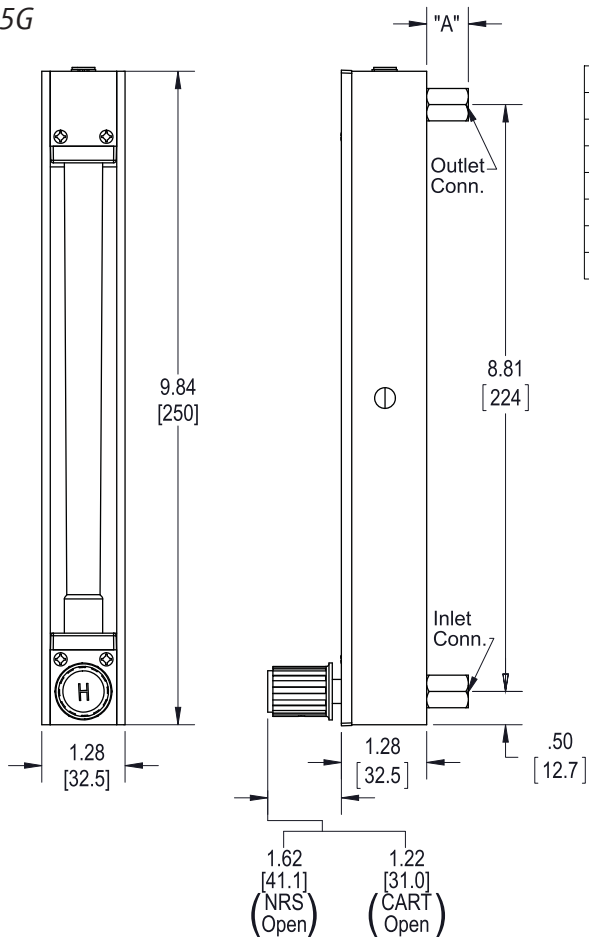

Dimension "A" Connection Adapter	
1/8" NPT	.625 [15.9]
1/4" NPT	.625 [15.9]
1/8" Compression	1.59 [40.3]
1/4" Compression	1.78 [45.1]
1/4" ID Hose	.72 [18.3]
1/4" Rc	.895 [22.7]
3/8" Rc	.895 [22.7]

Product Dimensions - Model 1350G/1355G with Flow Controller

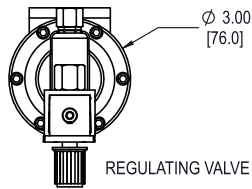

MODEL NO	SCALE LENGTH	A		B		C		C		D	
		INCH	MM	INCH	MM	OPEN INCH	OPEN MM	CLSD INCH	CLSD MM	INCH	MM
1350	65	7.31	185.7	4.34	110.3	2.79	70.8	2.65	67.2	6.38	162.0
1355	150	11.72	297.7	8.75	222.2	2.79	70.8	2.65	67.2	10.78	273.8

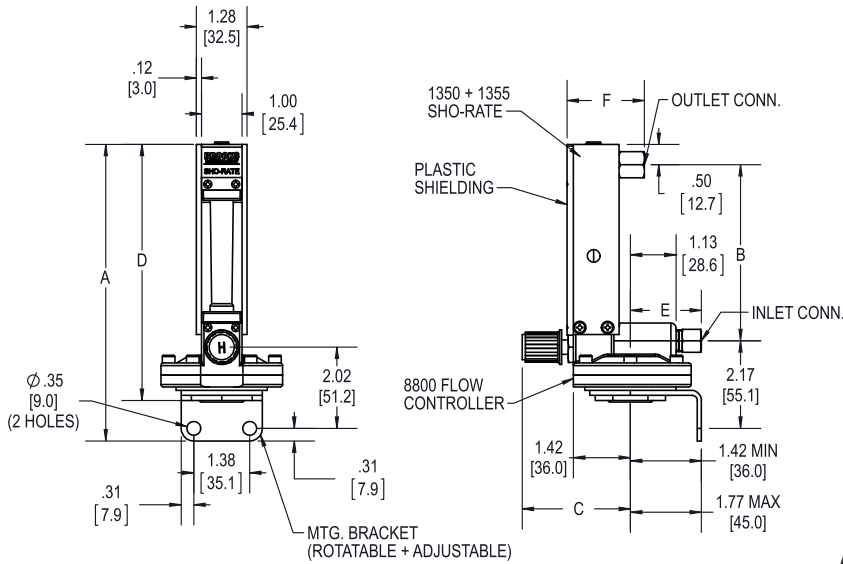

	INLET CONN.	INLET CONN.	OUTLET CONN.	OUTLET CONN.
CONN. SIZE	E	E	F	F
	INCH	MM	INCH	MM
1/8 NPT	1.85	46.9	1.91	48.4
1/4 NPT	1.13	28.6	1.91	48.4
1/8 COMP.	2.19	55.6	2.87	72.8
1/4 COMP.	2.28	57.8	3.06	77.6
1/4 I.D. HOSE	2.44	61.9	2.00	50.8
1/4 VCR (M)	N/A	N/A	2.19	55.6
1/4 Rc	2.10	53.3	2.18	55.3
3/8 Rc	2.60	66.1	2.18	55.3

Model 1350G/1355G with Model 8800 Flow Controller on Inlet

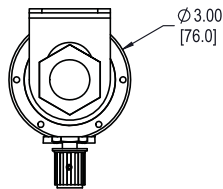

MODEL NO	SCALE LENGTH	A		B		C		C		D	
		INCH	MM	INCH	MM	OPEN INCH	OPEN MM	CLSD INCH	CLSD MM	INCH	MM
1350	65	7.31	185.7	4.34	110.3	2.79	70.8	2.65	67.2	6.38	162.0
1355	150	11.72	297.7	8.75	222.2	2.79	70.8	2.65	67.2	10.78	273.8

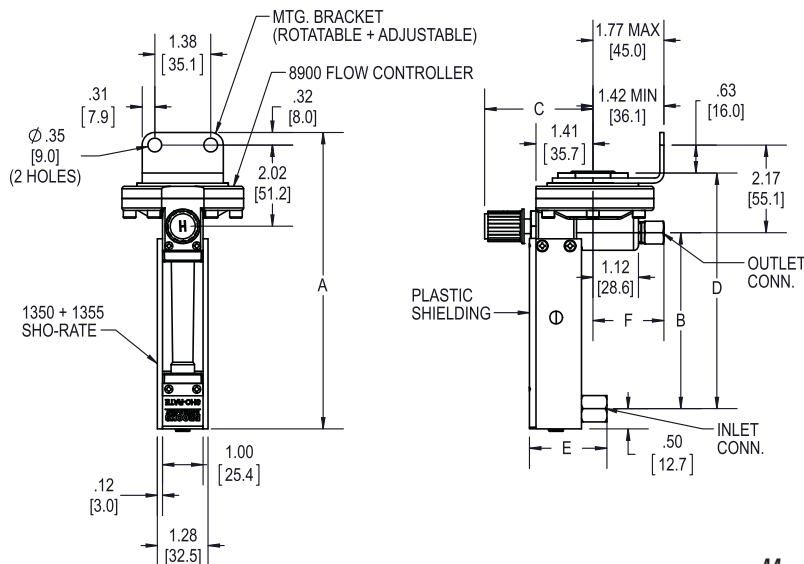

	INLET CONN.	INLET CONN.	OUTLET CONN.	OUTLET CONN.
CONN. SIZE	E	E	F	F
	INCH	MM	INCH	MM
1/8 NPT	1.91	48.4	1.85	46.9
1/4 NPT	1.91	48.4	1.13	28.6
1/8 COMP.	2.87	72.8	2.19	55.6
1/4 COMP.	3.06	77.6	2.28	57.8
1/4 I.D. HOSE	2.00	50.8	2.44	61.9
1/4 VCR (M)	2.19	55.6	N/A	N/A
1/4 Rc	2.18	55.3	2.10	53.3
3/8 Rc	2.18	55.3	2.60	66.1

Model 1350G/1355G with Model 8900 Flow Controller on Outlet

Ordering Information - Reference Model Code Tables

1. Model
2. Size, connections, type
3. Quantity required
4. Fluid
5. Minimum, normal and maximum operating temperature
6. Minimum, normal and maximum operating pressure (inlet and outlet)
7. Minimum, normal and maximum flow rate
8. Materials of construction
 - a. End fittings
 - b. Side plates
 - c. Bezel
 - d. Elastomers
9. Fluid
10. Fluid specific gravity
11. Fluid viscosity
12. Unusual system conditions (For ranges and pressure drops other than those listed, consult factory).
13. Optional equipment
 - a. Valve type and location
 - b. Flow controller and type

Model Code

Code Description	Code Option	Option Description	
I. Basic Model Number	1350	65mm Sho-Rate Size 1-6 Flow Indicator	
	1355	150mm Sho-Rate Size 1-6 Flow Indicator	
II. Model Revision Level	G	Revision G	
III. End Block Material	A	316 stainless steel	
	B	Brass	
IV. Tube		1350	1355
	A	-	R-2-15-A G
	B	-	R-2-15-B G
	C	-	R-2-15-C G
	D	-	R-2-15-D G
	E	-	R-6-15-A G
	F	-	R-6-15-B G
	G	R-2-65-A G	R-2-15-AAAA G
	H	R-2-65-B G	
	J	R-2-65-C G	
	K	R-2-65-D G	
	L	R-6-65-A G	
	M	R-6-65-B G	
	N*	No Tube	

**Notes: The options indicated are not available with a CRN certification.*

V. Float & Direct Read Scale Selection		Float	Accuracy	Scale Inscription
	ZZ**	None	N/A	N/A
	1A	*GLASS	STD-50(10%), 55(5%)	MM
	1B	*ST.STL	STD-50(10%), 55(5%)	MM
	1C	*SAPPHIRE	STD-50(10%), 55(5%)	MM
	1D	*CARBOLOY	STD-50(10%), 55(5%)	MM
	1E	*TANTALUM	STD-50(10%), 55(5%)	MM
	1G	GLASS	CALIB-50(5%), 55(3%)	MM
	1H	ST.STL	CALIB-50(5%), 55(3%)	MM
	1J	SAPPHIRE	CALIB-50(5%), 55(3%)	MM
	1K	CARBOLOY	CALIB-50(5%), 55(3%)	MM
	1L	TANTALUM	CALIB-50(5%), 55(3%)	MM
	2A	*GLASS	STD-50(10%), 55(5%)	LINEAR
	2B	*ST.STL	STD-50(10%), 55(5%)	LINEAR
	2C	*SAPPHIRE	STD-50(10%), 55(5%)	LINEAR
	2D	*CARBOLOY	STD-50(10%), 55(5%)	LINEAR
	2E	*TANTALUM	STD-50(10%), 55(5%)	LINEAR
	2G	GLASS	CALIB-50(5%), 55(3%)	LINEAR
	2H	ST.STL	CALIB-50(5%), 55(3%)	LINEAR
	2J	SAPPHIRE	CALIB-50(5%), 55(3%)	LINEAR
	2K	CARBOLOY	CALIB-50(5%), 55(3%)	LINEAR
	2L	TANTALUM	CALIB-50(5%), 55(3%)	LINEAR
	3A	*GLASS	STD-50(10%), 55(5%)	CUSTOM DECAL
	3B	*ST.STL	STD-50(10%), 55(5%)	CUSTOM DECAL
	3C	*SAPPHIRE	STD-50(10%), 55(5%)	CUSTOM DECAL
	3D	*CARBOLOY	STD-50(10%), 55(5%)	CUSTOM DECAL
	3E	*TANTALUM	STD-50(10%), 55(5%)	CUSTOM DECAL
	3G	GLASS	CALIB-50(5%), 55(3%)	CUSTOM DECAL
	3H	ST.STL	CALIB-50(5%), 55(3%)	CUSTOM DECAL
	3J	SAPPHIRE	CALIB-50(5%), 55(3%)	CUSTOM DECAL
	3K	CARBOLOY	CALIB-50(5%), 55(3%)	CUSTOM DECAL
	3L	TANTALUM	CALIB-50(5%), 55(3%)	CUSTOM DECAL
	4A	*GLASS	STD-50(10%), 55(5%)	PERCENT SCALE
	4B	*ST.STL	STD-50(10%), 55(5%)	PERCENT SCALE
	4C	*SAPPHIRE	STD-50(10%), 55(5%)	PERCENT SCALE
	4D	*CARBOLOY	STD-50(10%), 55(5%)	PERCENT SCALE
	4E	*TANTALUM	STD-50(10%), 55(5%)	PERCENT SCALE
	4G	GLASS	CALIB-50(5%), 55(3%)	PERCENT SCALE
	4H	ST.STL	CALIB-50(5%), 55(3%)	PERCENT SCALE
	4J	SAPPHIRE	CALIB-50(5%), 55(3%)	PERCENT SCALE
	4K	CARBOLOY	CALIB-50(5%), 55(3%)	PERCENT SCALE
	4L	TANTALUM	CALIB-50(5%), 55(3%)	PERCENT SCALE

**Accuracy for air and water in the preceding capacity tables will be STD-50(5%), 55(3%).*
*** Use this code (ZZ) only when Tube Code above is "N"*

Model Code (Continued)

Code Description	Code Option	Option Description
VI. Tube Packing and O-ring Materials		Tube Packing O-ring Meter/Valve
	A	Buna Buna
	B	Viton Viton
	C	Viton Teflon(mtr), Kalrez(vlv, jack screw)
	D	Viton EPR
	E	Viton Kalrez
	F	Teflon Buna
	G	Teflon Viton
	H	Teflon Teflon(mtr), Kalrez(vlv, jack screw)
	J	Teflon EPR
	K	Teflon Kalrez
	L	EPR EPR
	M	Butyl Butyl
	N	No Packing Buna
	P	No Packing Viton
	Q	No Packing Teflon(mtr), Kalrez(vlv, jack screw)
R	No Packing EPR	
S	No Packing Kalrez	
T	No Packing Butyl	
<i>Note: If valve assy is not required for a specific model number, select the proper code for the O-ring material of the Sho-Rate.</i>		
VII. End Fitting Composition		Fitting Material Connection Size and Type
	C	316SS 1/8" NPT
	*F	316SS 1/8" Thd.W/Locknut
	J	316SS 1/4" NPT
	* / ***K	KYNAR 1/4" NPT
	*N	316SS 1/4" Thd.W/Locknut
	R	316SS 1/8" Compression
	*U	316SS 1/8" Compression w/locknut (2 pc design)
	W	316SS 1/4" F-Rc Thd w/Locknut
	X	316SS 1/4" Compression
	*1	316SS 1/4" Compression w/locknut (2 pc design)
	3	316SS 3/8" F-Rc Thd w/Locknut
	***4	316SS 1/4" I.D.Hose
	*6	316SS Integral 5/16-24 thd.
	*7	316SS 1/4" VCR
	***8	316SS 6mm thd
<i>*Not valid for controllers ***The options indicated are not available with a CRN certification.</i>		
VIII. Valve Type	A	Valve Plug
	B	NRS-316SS #1
	C	NRS-316SS #2
	D	NRS-316SS #3
	E	NRS-316SS #4
	F	NRS-316SS #5
	G	NRS-316SS #6
	H	NRS-316SS #7
	J	To Integrally Mounted 88/8900 316SS Flow Controller - Cartridge II/III Valve - Viton Diaphragm
	K	To Integrally Mounted 88/8940 316SS Flow Controller - Cartridge II/III Valve - Viton Diaphragm
	L	To Integrally Mounted 88/8900 Brass Flow Controller - Cartridge II/III Valve - Viton Diaphragm
	M	To Integrally Mounted 88/8940 Brass Flow Controller - Cartridge II/III Valve - Viton Diaphragm
	N	To Integrally Mounted 88/8900 316SS Flow Controller - Cartridge II/III Valve - Teflon Diaphragm
	P	To Integrally Mounted 88/8940 316SS Flow Controller - Cartridge II/III Valve - Teflon Diaphragm
	Q	To Integrally Mounted 88/8900 Brass Flow Controller - Cartridge II/III Valve - Buna Diaphragm
	R	To Integrally Mounted 88/8940 Brass Flow Controller - Cartridge II/III Valve - Buna Diaphragm
	1	To Integrally Mounted 88/8900 316SS Flow Controller - NRS - Viton Diaphragm
	2	To Integrally Mounted 88/8940 316SS Flow Controller - NRS - Viton Diaphragm
	3	To Integrally Mounted 88/8900 Brass Flow Controller - NRS - Viton Diaphragm
	4	To Integrally Mounted 88/8940 Brass Flow Controller - NRS - Viton Diaphragm
	5	To Integrally Mounted 88/8900 316SS Flow Controller - NRS - Teflon Diaphragm
	6	To Integrally Mounted 88/8940 316SS Flow Controller - NRS - Teflon Diaphragm
	7	To Integrally Mounted 88/8900 Brass Flow Controller - NRS - Buna Diaphragm
8	To Integrally Mounted 88/8940 Brass Flow Controller - NRS - Buna Diaphragm	
S	Std. Valve Cavity - no valve assy or plug	
T	Cartridge II/III Valve - Low Flow - 316SS	
U	Cartridge II/III Valve - Med Flow - 316SS	
V	Cartridge II/III Valve - HighFlow - 316SS	

Model Code (Continued)

Code Description	Code Option	Option Description
IX. Valve Cavity/Controller Location & Connection Orientation		Valve/Controller Location
		Connection Orientation
		Inlet Outlet
	1	Inlet Back Back
	5	Outlet Back Back
	9	n/a Back Back
X. Accessories	A	None
	B*	Bistable Alarm 1 Initiator
	C*	Bistable Alarm 2 Initiators
	D*	Bistable Alarm 1 Initiator with I.S. Relays 240V
	E*	Bistable Alarm 2 Initiators with I.S. Double Relays 240V
	F*	Bistable Alarm 1 Initiator with I.S. Relay 120V
	G*	Bistable Alarm 2 Initiators with I.S. Double Relays 120V
	H	Aluminum Flush Bezel for Stainless Meters
	K	Panel Mount Screws
<i>*Notes: Not yet available. Release TBD</i>		
XI. Options	A	None
	B	316 Stainless Steel Frame
	C	Baseplate (Aluminum)
	D	No Brooks Identification
	E	316SS Frame & No Brooks ID
	F	Baseplate & No Brooks ID
	G	316SS Frame & Baseplate
	H	316SS Frame & Baseplate & No Brooks ID
	J	Stainless Steel Tag & 316SS Frame
	K	Stainless Steel Tag & Baseplate (Aluminum)
	L	Stainless Steel Tag & no Brooks ID
	M	Stainless Steel Tag & 316SS Frame & No Brooks ID
	N	Stainless Steel Tag & Baseplate & No Brooks ID
	P	Stainless Steel Tag & 316SS Frame & Baseplate
	Q	Stainless Steel Tag & 316SS Frame & Baseplate & No Brooks ID
	R	Stainless Steel Tag
	S*	Stainless Steel Float Stops
	T	316SS Frame & Stainless Steel Float Stops
U	316SS Frame & Stainless Steel Float Stops & Stainless Steel Tag	
<i>*Notes: Not yet available. Release TBD</i>		
XII. Certifications	A	None
	B	CRN Certification
	C	International Calibration Certification (10%-1350, 5%-1355)
	D	Degrease for Oxygen Service (not MIL Spec)
	E	CRN Cert & ICC
	F	CRN Cert & Degrease for O2
	G	Degrease for O2 & ICC

Sample Standard Model Code

I	II	III	IV	V	VI	VII	VII	IX	X	XI
1350	G	G	1B	F	C	L	2	A	A	A

Brooks Service and Support

Brooks is committed to assuring all of our customers receive the ideal flow solution for their application, along with outstanding service and support to back it up. We operate first class repair facilities located around the world to provide rapid response and support. Each location utilizes primary standard calibration equipment to ensure accuracy and reliability for repairs and recalibration and is certified by our local Weights and Measures Authorities and traceable to the relevant International Standards.

Visit www.BrooksInstrument.com to locate the service location nearest to you.

START-UP SERVICE AND IN-SITU CALIBRATION

Brooks Instrument can provide start-up service prior to operation when required. For some process applications, where ISO-9001 Quality Certification is important, it is mandatory to verify and/or (re)calibrate the products periodically. In many cases this service can be provided under in-situ conditions, and the results will be traceable to the relevant international quality standards.

CUSTOMER SEMINARS AND TRAINING

Brooks Instrument can provide customer seminars and dedicated training to engineers, end users, and maintenance persons.

Please contact your nearest sales representative for more details.

HELP DESK

In case you need technical assistance:

Votre contact Brooks Instrument :
Serv'Instrumentation
Z.I Broteau Nord
69540 Irigny
France
Tél : +33 (0)4 78 51 47 50
Fax : +33 (0)4 78 51 59 96
Email : e-serv@servinstrumentation.fr
Web : www.servinstrumentation.fr

Due to Brooks Instrument's commitment to continuous improvement of our products, all specifications are subject to change without notice.

TRADEMARKS

Brooks, NRS, Sho-Rate Brooks Instrument, LLC

All other trademarks are the property of their respective owners.

