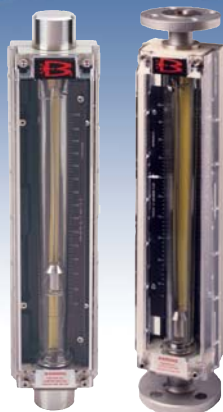

Model  
GT1020

Model  
GT1024

# Glass Tube Flowmeter Model GT1000

**Variable Area**

## Industrial Glass Tube, Variable Area Flowmeters

### Description

The Brooks® GT 1000 combines ruggedness and simplicity in design to provide a versatile glass tube flowmeter suitable for a wide range of applications. The GT 1000 O-ring construction minimizes process downtime by allowing for convenient in-line removal of the glass tube for cleaning and maintenance.

### Features

- Brass or 316L SS (1.4404) end fittings
- Flanged or threaded connections
- Horizontal or vertical connections
- Horizontal end fittings 360 degrees rotatable
- Standard accuracy +2% full scale / Class 2.5 acc VDI/VDE
- Epoxy painted cast aluminum frame with outstanding environmental resistance
- Fluid resistant O-ring design allows tube removal without removal from the process piping

### Product Specifications

<b>Capacities and Pressure Drops</b>	See Capacities and Pressure Drop Tables
<b>Flow Accuracy</b>	Standard: $\pm 2\%$ Full Scale, Class 2.5 acc VDI/VDE
	Optional: $\pm 1\%$ Full Scale, Class 1.6 acc VDI/VDE
<b>Repeatability</b>	$\leq 0.5\%$ Full Scale
<b>Pressure Ratings/PED Categories</b>	See Pressure Ratings/PED Categories Tables for maximum non-shock pressure
<b>Scales</b>	Single or dual detachable aluminum plate
	Nominal Lengths: 127mm, 200mm and 250mm
	Graduations: Choice of direct reading units, millimeter or percentage of maximum flow with factor tag
<b>Ambient Temperature Limits</b>	33 to 125°F (1°C to 52°C)
<b>Operating Fluid Temperature Limits (Meter)</b>	Maximum: 250°F (121°C)
	Minimum: 33°F (1°C)
<b>Operating Fluid Temperature Limits (Alarms)</b>	Maximum: 250°F (121°C) - Reed Switch
	Maximum: 167°F (75°C) - Inductive Switch - Refer to Inductive Alarm Temperature Limits
	Minimum: 33°F (1°C) - Reed Switch/Inductive Switch
<b>Dimensions</b>	See Dimensions Figures
<b>Optional Equipment</b>	Mounting hardware for flush or front of panel

## Product Specifications (continued)

<b>Materials of Construction</b>	
<b>Metering Tube</b>	Borosilicate glass
<b>Window</b>	Polycarbonate with UV inhibitor
<b>Floats</b>	Size 2 and 6: Sapphire, glass, Carboloy®, 316 stainless steel Size 7: Glass, 316 stainless steel Sizes 8-13: 316 stainless steel
<b>Float Stops</b>	Size 2, 6, 12 and 13: Teflon® Size 7, 8, 9 and 10: 316 stainless steel springs
<b>Housing</b>	Cast Aluminum with Epoxy paint
<b>End Fittings</b>	Brass or 316/316L stainless steel (1.4404)
<b>O-rings</b>	Viton® fluoroelastomers, Buna-N, Kalrez® perfluoroelastomers (Stainless steel body only), EPDM (Stainless steel body only)
<b>Hardware</b>	Stainless steel
<b>Connections</b>	Brass or stainless steel fittings: NPT or BSPT/RC female connections Stainless steel fittings: 150 lbs. flanges per ANSI B 16.5
<b>Connection Orientation</b>	Vertical or horizontal on inlet and/or outlet
<b>Certifications</b>	International Calibration Certificate Material Certification to DIN 3.1 Declaration of Compliance 2.1 Oxygen Service

### GT1000 Pressure Ratings and PED Categories

Maximum Operating Pressure (PSIG/bar) at Fluid Temperature: Up to 250°F (121°C)			
Meter Size	NPT Threaded Connections	ANSI 150# RF Flanged Connections	PED Category
2	500/34.5	240/16.5	SEP
6	450/31	240/16.5	SEP
7	300/20.7	240/16.5	SEP
8	250/17	240/16.5	SEP
9	200/13.8	200/13.8	SEP
10	175/12.1	175/12.1	SEP
12	100/6.9	100/6.9	See Note
13	75/5.2	75/5.2	See Note

Note: Size 12 and 13 do not conform to Pressure Equipment Directive 97/23/EC, therefore cannot be sold or used in the EU/EFTA.

## Product Specifications - Capacities and Pressure Drop

### Meter Sizes 2 & 6: Spherical Floats

TUBE	SPHERICAL FLOAT	WATER					AIR*			
		Flow Rate		Pressure Drop		V. I. C.**	Flow Rate		Pressure Drop	
		cc/min.	l/h	Inches WC	kPa		slpm	m3/nh	Inches WC	kPa
SIZE 2 R-2-127-AAAAT	GLASS	0.42	0.025	0.3	0.08	1.0	0.039	0.0021	0.3	0.08
	SAPPHIRE	0.84	0.05	0.4	0.09	1.0	0.06	0.0033	0.4	0.1
	316 SS	1.9	0.11	0.7	0.17	1.0	0.11	0.0066	0.8	0.19
	CARBOLOY	3.9	0.23	1.1	0.27	1.0	0.2	0.011	1.2	0.3
SIZE 2 R-2-127-DT	GLASS	4.2	0.25	0.3	0.08	1.0	0.3	0.016	0.3	0.08
	SAPPHIRE	8.0	0.48	0.4	0.1	1.0	0.41	0.023	0.4	0.11
	316 SS	16	0.98	0.9	0.22	1.0	0.68	0.038	1.0	0.24
	CARBOLOY	27	1.6	1.5	0.38	1.0	1.0	0.057	1.7	0.42
SIZE 2 R-2-127-BT	GLASS	47	2.8	0.6	0.16	1.0	2.0	0.11	0.7	0.18
	SAPPHIRE	71	4.2	0.8	0.21	1.0	2.7	0.15	0.9	0.23
	316 SS	110	7.1	1.8	0.45	1.0	4.1	0.23	2.0	0.51
	CARBOLOY	170	10	3.0	0.75	1.0	5.9	0.33	3.3	0.83
SIZE 6 R-6-127-AT	GLASS	160	10	1.8	0.45	1.0	7.3	0.4	2.0	0.5
	SAPPHIRE	240	14	2.9	0.72	1.0	9.4	0.52	3.2	0.8
	316 SS	410	24	6.1	1.53	1.0	14	0.78	6.8	1.7
	CARBOLOY	610	36	10.5	2.61	1.0	19	1.1	11.6	2.9
SIZE 6 R-6-127-BT	GLASS	450	27	9.4	2.34	1.0	19	1.0	10.4	2.6
	SAPPHIRE	660	40	14.9	3.7	1.0	24	1.3	16.5	4.1
	316 SS	1000	65	30.1	7.5	1.0	35	1.9	33.3	8.3
	CARBOLOY	1500	95	57.8	14.4	1.0	49	2.7	64.2	16

Note: 316 SS and Carboloy float capacities listed above can be used to size meters with optional inductance-type alarms

(\*) Air flow rates in standard units are at 70°F and 14.7 PSIA, air flow rates in normal units are at 1.013 bar & 20°C

(\*\*) When the viscosity of the fluid exceeds the viscosity immunity ceiling (VIC), a calculated correction is applied to account for the difference between factory calibration fluid and process fluid.

# Product Specifications - Capacities and Pressure Drop (continued)

Meter Sizes 7, 8, 9, 10, 12 & 13: 200mm, 250mm Scale, Rib Guided Tubes, Standard Floats

TUBE	FLOAT	Water					Air****					
		Flow Rate		Pressure Drop		V. I. C.**	Flow Rate		Pressure Drop		REQ. psi (*)	REQ. bar(*)
		GPM	l/h	INCHES W.C.	kPa		SCFM	m3n/h	INCHES W.C.	kPa		
Size 7 R-7M-25-1FT	GLASS	0.16	36	2.0	0.5	1.0	0.88	1.4	2.0	0.5	0	0
	316 SS	0.38	86	3.0	0.75	1.0	1.6	2.6	4.0	1	0	0
	8-RV-3	0.77	170	3.0	0.75	2.0	3.1	5.0	3.0	0.75	0	0
Size 8 8-8M-25-4FT	8-RV-8	1.0	240	5.0	1.3	3.7	4.4	7.0	5.0	1.3	0	0
	8-RS-8	1.3	310	6.0	1.5	1.8	5.8	9.2	6.0	1.5	0	0
	8-RS-14	1.8	410	10	2.5	1.9	7.5	11	11	2.8	0	0
	8-RV-14	1.4	320	8.0	2	5.4	5.8	9.2	8.0	2	0	0
	8-RV-31	2.0	460	16	4	7.0	8.3	13	17	4.3	30	2
	8-RS-31	2.5	580	20	5	3.1	10	16	22	5.5	30	2
	8-LJ-48 ****	4.8	1100	52	13	1.0	20	33	57	14	30	2
Size 9 R-9M-25-3FT	9-RV-33	2.5	570	6.0	1.5	11	10	16	7.0	1.8	0	0
	9-RS-33	3.2	730	4.0	1	2.4	13	21	8.0	2.0	0	0
	9-RV-87	3.9	890	14	3.5	17	16	26	16	4.0	30	2
	9-RS-87	5.1	1100	18	4.5	3.5	21	35	19	4.8	30	2
Size 10 R-10M-25-3FT	10-RV-64	6.2	1400	12	3	15	25	40	14	3.5	0	0
	10-RS-64	7.8	1700	16	4	3.7	32	50	18	4.5	0	0
	10-RS-138	10	2400	30	7.5	5.5	46	76	36	9	30	2
	10-LJ-238 ****	20	4600	104	26	1.0	92	150	16	4	30	2
Size 12 R-12M-20-5FT	12-RV-119	13	2900	4.0	1	30	56	88	4.0	1	0	0
	12-RV-221	17	3900	10	2.5	32	70	110	12	3	0	0
	12-RV-343	20	4700	16	4	24	86	140	20	5	30	2
	12-HF-455 ****	42	9700	30	7.5	10	170	280	32	8	30	2
Size 13 R-13M-20-3FT	13-RV-510	31	7200	26	6.5	40	130	200	28	7	0	0
	13-RS-510	42	9600	36	9	20	170	270	40	10	0	0
	13-HF-758 ****	62	14000	40	10	12	270	440	44	11	30	2
	13-LJ-1394 ****	98	22000	200	50	1.0	NOT INTENDED FOR GAS SERVICE					

(\*) Minimum operating downstream pressure for gas service in PSIG.

(\*\*) Viscosity immunity ceiling listed is for stainless steel float, fluid specific gravity 1.0. When the viscosity of the fluid exceeds the viscosity immunity ceiling (VIC), a calculated correction is applied to account for the difference between factory calibration fluid and process fluid.

(\*\*\*\*) Extended range - nonviscosity compensating floats.

(\*\*\*\*\*) Air flow rates in standard units are at 70°F and 14.7 PSIA, air flow rates in normal units are at 1.013 bar & 20°C

Meter Sizes 2 thru 13: 127mm, 200mm, 250mm Scale, Rib Guided Tubes, Alarm Floats

TUBE	FLOAT	Water					Air****					
		Flow Rate		Pressure Drop		V. I. C.**	Flow Rate		Pressure Drop		REQ. psi(*)	REQ. bar(*)
		GPM	l/h	INCHES W.C.	kPa		SCFM	m3n/h	INCHES W.C.	kPa		
Size 2		Refer to Capacity Table for Sizes 2 & 6***										
Size 6		Refer to Capacity Table for Sizes 2 & 6***										
Size 7 R-7M-25-1FT	7-XV-11A	0.48	100	8.0	2.0	3.0	1.9	3.0	10	2.5	0	0
Size 8 R-8M-25-4FT	8-XV-14	1.4	320	8.0	2.0	5.4	6	9.2	8.0	2.0	0	0
	8-XS-14	1.8	410	10	2.5	1.9	8	11	11	2.8	0	0
Size 9 R-9M-25-3FT	9-XV-40	2.8	630	6.0	1.5	11	10	18	7.0	1.8	0	0
	9-XS-40	3.5	810	4.0	1.0	2.4	13	22	8.0	2.0	0	0
Size 10 R-10M-25-3FT	10-XV-64	6.2	1400	11	2.8	15	25	40	13	3.3	0	0
	10-XS-138	10	2400	30	7.5	5.5	45	75	36	9.0	30	2
Size 12 R-12M-20-5FT	12-XV-221	17	3900	10	2.5	29	70	110	12	3.0	0	0
	12-XV-343	20	4700	16	4.0	36	94	150	18	4.5	30	2
Size 13 R-13M-20-3FT	13-XV-510	31	7200	26	6.5	42	130	200	28	7.0	0	0
	13-XS-510	42	9600	36	9.0	7.6	170	270	40	10	0	0
	13-XHF-758	62.00	14000	40	10	1.0	270	450	44	11	30	2

(\*) Minimum operating downstream pressure for gas service (psig)

(\*\*) Viscosity immunity ceiling listed is for stainless steel float, fluid specific gravity 1.0. When the viscosity of the fluid exceeds the viscosity immunity ceiling (VIC), a calculated correction is applied to account for the difference between factory calibration fluid and process fluid.

Note 1: All size 8-13 floats listed are 316 SS with integral magnet for use with reed switch alarm.

(\*\*\*\*) Alarm option for sizes 2 and 6 requires metallic float (SS or carbonyl) for use with inductive type alarm.

(\*\*\*\*\*) Air flow rates in standard units are at 70°F and 14.7 PSIA, air flow rates in normal units are at 1.013 bar & 20°C

## Float Types



### Spherical

Lowest meter capacity or medium capacity with low viscosity fluids.

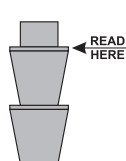

### Type LJ

Maximum flowmeter capacity with limited viscosity immunity.

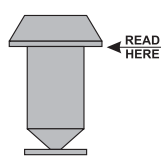

### Type RV (rib guided)

Highest immunity to viscous fluids with medium meter capacity. (most stable)

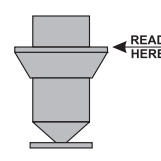

### Type RS (rib guided)

High flow capacity with some immunity to viscous fluids.

(Descriptions refer to floats used in the same size tube)

# Product Dimensions - GT1000 Family: NPT, Flanged and w/Alarm Options

## NPT Connections

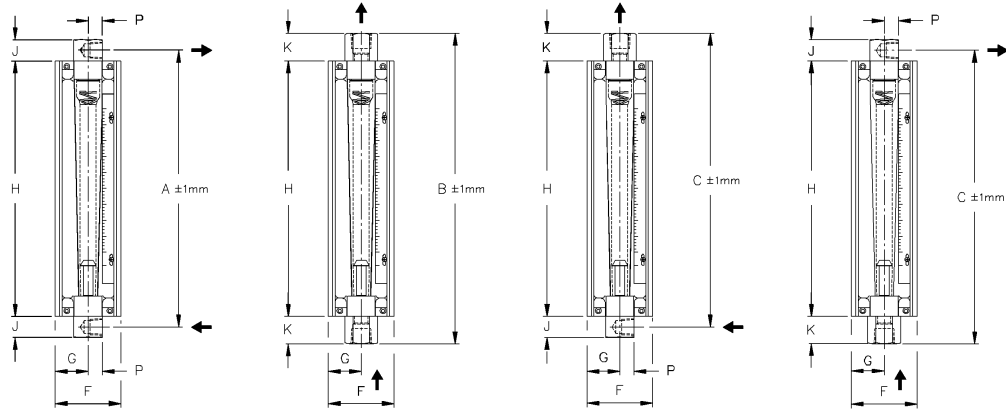

## Flanged Connections

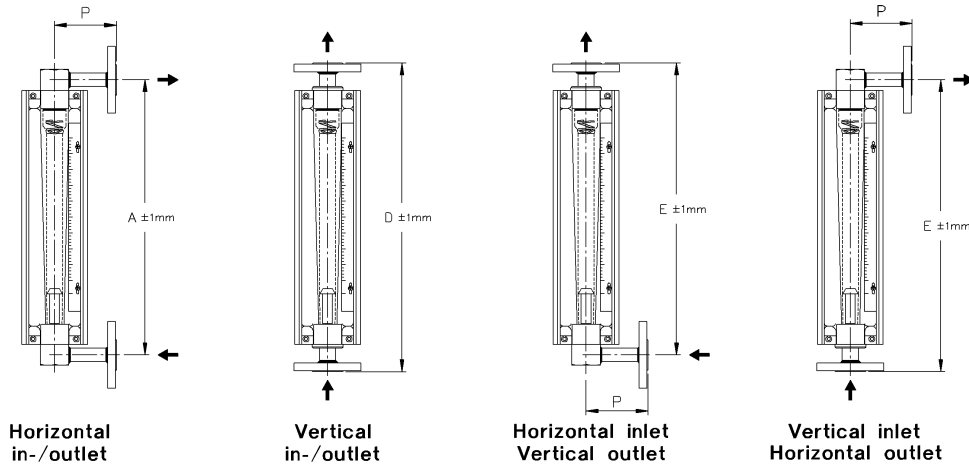

## Alarm Options

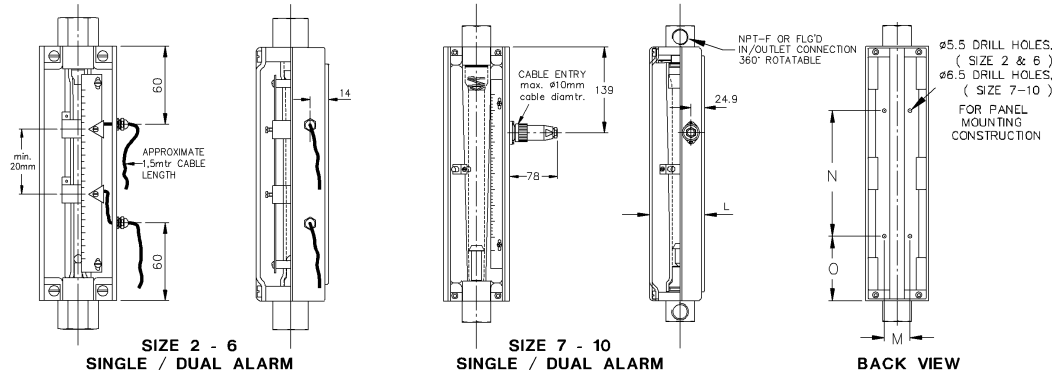

	A	B	C	D	E	F	G	H	J	K	L	M	N	O
SIZE 2-6	218 [8.58"]	250 [9.84"]	235 [9.25"]	270 [10.60"]	245 [9.65"]	60 [2.36"]	30 [1.18"]	196 [7.72"]	23 [0.91"]	27 [1.06"]	56 [2.20"]	25.4 [1.00"]	101.5 [4.00"]	47 [1.85"]
SIZE 7-10	445 [17.50"]	500 [19.70"]	473 [18.60"]	500 [19.70"]	473 [18.60"]	105 [4.13"]	53 [2.09"]	410 [16.10"]	35 [1.38"]	45 [1.77"]	90 [3.54"]	41.5 [1.63"]	203 [7.99"]	104 [4.09"]
SIZE 12-13	520 [20.50"]	500 [19.70"]	510 [20.10"]	500 [19.70"]	510 [20.10"]	146 [5.75"]	73 [2.87"]	414 [16.30"]	54 [2.13"]	43 [1.69"]	141 [5.55"]	N.A.	N.A.	N.A.

	CONNECTION	P
SIZE 2-6	1/4" NPT-F	13,5 [0.531"]
	1/2" FLANGED	75 [2.95"]
SIZE 7-8	1/2" NPT-F	23 [0.906"]
	1/2" FLANGED	100 [3.94"]
SIZE 9-10	3/4" NPT-F	23 [0.906"]
	1" FLANGED	120 [4.72"]
SIZE 12-13	1 1/2" NPT-F	44 [1.73"]
	1 1/2" FLANGED	130 [5.12"]

## GT1000 Optional Equipment - Alarms & Valves

### GT1000 Alarm Contacts Meter Sizes 7 to 13

The Brooks reed switch alarm is a normally open, latching switch used in conjunction with the GT1000 glass tube flow meter for signaling high and/or low flow or a deviation from a flow setting.

A magnet embedded and sealed in the float actuates the alarm switch. The reed switch is mounted adjacent to the flow tube and is easily adjustable over the entire flow range of the instrument.

The sealed reed switch consists of a biasing magnet and hermetically sealed reed switch, which is insulated to prevent damage from mild shock and normal pipe vibration. The contact rating of the switch is very low.

An external relay is recommended for secure operation. Plus the external relay can be configured to operate as a normally open or normally closed state which provides totally flexibility of operation.

### Alarm Certifications

#### Data Reed Switch

Maximum Voltage\* 175 Vdc, 124 Vac

Maximum Current\* 250 mA

Maximum Contact Rating\* 3 Watts

\*(Maximum Switch Specifications)

### Electrical Classification

#### Non Incendive:

Maximum Voltage 30 Vdc

Maximum Current 250 mA

Maximum Contact Rating 3 Watts



US and Canada E73889

NI Class I, Div 2, Groups A, B, C and D:  
Class II, Groups F and G, T6.  
per UL 1604, Third Edition

Environmental rating: Type 4X

### Intrinsically Safe:

Entity parameters:

$V_{max} = U_i = 30 \text{ Vdc}$ ,  $I_{max} = 100 \text{ mA}$ ,  $C_i = 0$ ,  $L_i = 0$



US and Canada E73889

IS Class I, II, III, Div 1, Groups A, thru G, T6  
per UL 913: Sixth Edition

Environmental rating: Type 4X

### Inductive Alarms,

#### Alarm Contacts Meter Sizes 2 and 6

Inductive coils for high and/or low flow alarm may be mounted to the instrument to create a highly sensitive, stable and accurate device for signaling high or low flows or deviations from a controlled flow. The inductive alarm can only be used in combination with 316 ss or Carboloy® ball floats. The alarm points may be adjusted over the entire flowmeter range and be set so that any two contacts may be made to operate simultaneously. For hazardous area applications Brooks can supply an approved Namur power supply/ amplifier/relay unit to obtain an intrinsically safe current circuit.

#### Data 10&15-14-N3 Inductive Coils

<b>Power Supply</b>	8 volt nominal (max. 15.5 Vdc)
Current Consumption	Active area clear: > 3 mA
Current Consumption	Active area obscured: < 1 mA
Self Inductance	70 $\mu\text{H}$
Self Capacitance	90 nF
Max. Temperature	Refer to chart
<b>Electrical Classification</b>	
<b>Intrinsically Safe:</b>	
ATEX:	PTB99ATEX2128X
	Ex II 2 G
	EEx ia IIC T6
Enclosure Type:	IP67
EMC Directive:	EN 60947-5-2 DIN EN 60947-5-6 (Namur)

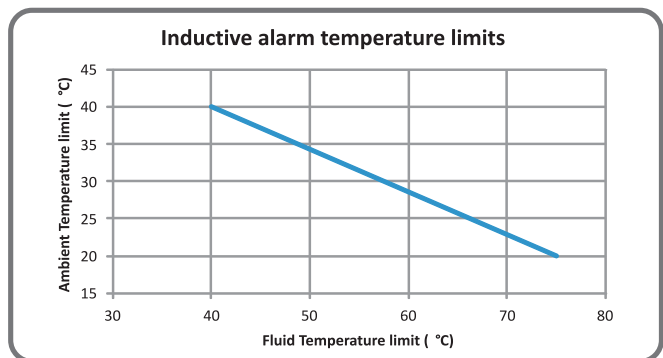

### Alarm Hysteresis

8mm typical (0.32 in)

### Alarm Accessories

Remotely mounted, switch isolator/power supplies are required for inductive alarms and recommended for reed switch alarms. One or two single-pole, double-throw (SPDT) relays are available with either 110 or 220 AC volt units.

### Optional Needle Valves

For flow rate control, needle valves are externally piped to either the inlet or outlet connection of the meter. Valves are available with threaded or flanged connections. Note, solenoid valves should not be used because this type of valve can cause pressure shocks which can damage the glass tube.

**Note: Valves are supplied separately.**

## Model Code

Code Description	Code Option	Option Description								
I. Base Model Numbers	<b>1020N</b>	Horizontal Inlet and Outlet								
	<b>1024N</b>	Vertical Inlet and Outlet								
	<b>1026N</b>	Horizontal Inlet and Vertical Outlet								
	<b>1027N</b>	Vertical Inlet and Horizontal Outlet								
II. Size and Tube Designator		Size	Tube							
	<b>Q</b>	Size 2	R-2-127-AAAAT							
	<b>C</b>	Size 2	R-2-127-DT							
	<b>E</b>	Size 2	R-2-127-BT							
	<b>G</b>	Size 6	R-6-127-AT							
	<b>H</b>	Size 6	R-6-127-BT							
	<b>J</b>	Size 7	R-7M-25-1FT							
	<b>K</b>	Size 8	R-8M-25-4FT							
	<b>L</b>	Size 9	R-9M-25-3FT							
	<b>M</b>	Size 10	R-10M-25-3FT							
<b>N</b>	Size 12	R-12M-20-5FT (Not available in EU)								
<b>P</b>	Size 13	R-13M-20-3FT (Not available in EU)								
III. Alarms		Switch	Relay							
	<b>0</b>	None	None							
	<b>1</b>	1 Switch/Sensor	No Relay							
	<b>2</b>	2 Switches/Sensors	No Relay							
	<b>3</b>	1 Switch/Sensor	220 Vac IS Dual Relay (SPDT)							
	<b>4</b>	2 Switches/Sensors	220 Vac IS Dual Relay (SPDT)							
	<b>5</b>	1 Switch/Sensor	110 Vac IS Dual Relay (SPDT)							
<b>6</b>	2 Switches/Sensors	110 Vac IS Dual Relay (SPDT)								
IV. Floats		Size 2	Size 6	Size 7	Size 8	Size 9	Size 10	Size 12	Size 13	
	Standard Floats Size 2, 6 & 7	<b>1</b>	Glass	Glass	Glass	-	-	-	-	-
		<b>2</b>	Sapphire	Sapphire	-	-	-	-	-	-
	Alarm Floats Size 2, 6 & 7	<b>3</b>	316 SS	316 SS	316 SS	-	-	-	-	-
		<b>4</b>	Carboloy	Carboloy	-	-	-	-	-	-
	Standard Floats Size 8-13	<b>A</b>	-	-	-	-	9-RV-33	10-RV-64	12-RV-119	13-RV-510
		<b>B</b>	-	-	-	8-RV-3	9-RS-33	10-RS-64	12-RV-221	13-RS-510
		<b>C</b>	-	-	-	8-RV-8	9-RV-87	-	12-RV-343	-
		<b>D</b>	-	-	-	8-RS-8	9-RS-87	10-RS-138	-	-
		<b>E</b>	-	-	-	8-RV-14	-	10-LJ-238	12-HF-455	13-HF-758
		<b>F</b>	-	-	-	8-RS-14	-	-	-	13-LJ-1394
		<b>G</b>	-	-	-	8-RV-31	-	-	-	-
		<b>H</b>	-	-	-	8-RS-31	-	-	-	-
	Alarm Floats Size 7-13	<b>J</b>	-	-	-	8-LJ-48	-	-	-	-
		<b>N</b>	-	-	7-XV-11A	8-XV-14	9-XV-40	10-XV-64	12-XV-221	13-XV-510
<b>P</b>		-	-	-	8-XS-14	9-XS-40	-	12-XV-343	13-XS-510	
<b>R</b>		-	-	-	-	-	10-XS-138	-	-	
<b>S</b>		-	-	-	-	-	-	-	13-XHF-758	
V. End Fitting Material and Certification	<b>1</b>	Brass								
	<b>2</b>	316 Stainless Steel								
	<b>4</b>	316 Stainless Steel with Material Certificate 3.1								
VI. O-ring Material	<b>A</b>	Viton								
	<b>B</b>	Buna								
	<b>C</b>	Kalrez								
	<b>D</b>	EPDM								
VII. Connection Type	<b>A</b>	NPT-F Threaded								
	<b>B</b>	RC (BSP) Threaded								
	<b>C</b>	ANSI 150# RF Flange								
VIII. Connection Size	<b>1</b>	1/4"								
	<b>2</b>	1/2"								
	<b>3</b>	3/4"								
	<b>4</b>	1"								
	<b>5</b>	1-1/2"								

## Model Code (continued)

Code Description	Code Option	Option Description
IX. Right Side Scale Inscription (When facing meter)	9	No scale required at this location
	A	No inscription (blank scale)
	B	MM scale
	C	PERCENT scale - fluid GAS
	D	PERCENT scale - fluid LIQUID
	E	Direct Reading scale - fluid LIQUID
	F	Direct Reading scale - fluid GAS
X. Left Side Scale Inscription (When facing meter)	9	No scale required at this location
	A	No inscription (blank scale)
	B	MM scale
	C	PERCENT scale - fluid GAS
	D	PERCENT scale - fluid LIQUID
	E	Direct Reading scale - fluid LIQUID
	F	Direct Reading scale - fluid GAS
XI. Meter Accuracy	C	2% Full Scale
	D	2% Full Scale and Certification to ICC
	E	1% Full Scale
	F	1% Full Scale and Certification to ICC
	J	2.5 VDI
	L	1.6 VDI
XII. Needle Valve/Flow Controller	0	None
	A	Valve on Inlet
	B	Valve on Outlet
XIII. Panel Mounting	0	None
	1	Front Panel Mounting
	2	Back Panel Mounting
XIV. Processes with Certificates	0	None
	A	Declaration of Compliance 2.1 Oxygen Service
XV. Additional Certificate Requirements	0	None
	B	International Calibration Certificate
XVI. OEM	1	Standard
	2	No Brooks Identification

### Sample Standard Model Code

I	II	II	IV	V	VI	VII	VIII	IX	X	XI	XII	XIII	XIV	XV	XVI
1020N	K	0	B	2	A	A	3	E	9	C	0	0	0	0	1

## GT1000 - Approximate Shipping Weights

METER SIZE	NPT CONNECTIONS	FLANGED CONNECTIONS
	SHIPPING WEIGHT	SHIPPING WEIGHT
2 TO 6	7 / 3.2	10 / 4.5
7 AND 8	12 / 5.5	13 / 5.9
9	18 / 6.2	20 / 9
10	25 / 11.4	29 / 13.2
12	39 / 17.7	49 / 22.3
13	40 / 18.2	52 / 23.6

## Brooks Service and Support

Brooks is committed to assuring all of our customers receive the ideal flow solution for their application, along with outstanding service and support to back it up. We operate first class repair facilities located around the world to provide rapid response and support. Each location utilizes primary standard calibration equipment to ensure accuracy and reliability for repairs and recalibration and is certified by our local Weights and Measures Authorities and traceable to the relevant International Standards.

Visit [www.BrooksInstrument.com](http://www.BrooksInstrument.com) to locate the service location nearest to you.

### START-UP SERVICE AND IN-SITU CALIBRATION

Brooks Instrument can provide start-up service prior to operation when required. For some process applications, where ISO-9001 Quality Certification is important, it is mandatory to verify and/or (re)calibrate the products periodically. In many cases this service can be provided under in-situ conditions, and the results will be traceable to the relevant international quality standards.

### CUSTOMER SEMINARS AND TRAINING

Brooks Instrument can provide customer seminars and dedicated training to engineers, end users, and maintenance persons.

Please contact your nearest sales representative for more details.

### HELP DESK

In case you need technical assistance:

Votre contact Brooks Instrument :  
Serv'Instrumentation  
Z.I Broteau Nord  
69540 Irigny  
France  
Tél : +33 (0)4 78 51 47 50  
Fax : +33 (0)4 78 51 59 96  
Email : [e-serv@servinstrumentation.fr](mailto:e-serv@servinstrumentation.fr)  
Web : [www.servinstrumentation.fr](http://www.servinstrumentation.fr)

Due to Brooks Instrument's commitment to continuous improvement of our products, all specifications are subject to change without notice.

#### TRADEMARKS

Brooks ..... Brooks Instrument, LLC  
Carboloy ..... General Electric Co.  
Kalrez ..... DuPont Dow Elastomers  
Teflon ..... E.I. DuPont de Nemours & Co.  
Viton ..... DuPont Performance Elastomers

