



6" Mechanical BiRotor Models B090, B091, B093, B094, B095

Design Specifications
DSMB09X
Revision 03

Description

The BiRotor Meter is a positive displacement meter utilized in the most demanding applications requiring accuracy, long life and ruggedness.

Accuracy is attained by the unique BiRotor design which features two finely balanced rotors. An adjuster, incorporated on the meter, is used to assure maximum accuracy within the meter's flow range.

Long Life is assured because the meter does not contain any oscillating, reciprocating, sliding parts or cranks to wear or disturb the balanced rotary action. In addition, the materials incorporated within the meter assembly are selected specifically for a wide range of petroleum and industrial liquid applications.

Principle of Operation

Two spiral fluted rotors within the measuring unit are dynamically balanced to minimize bearing wear. (Refer to Figure 1). As the product enters the intake of the measuring unit, the two rotors divide the product into precise segments of volume momentarily and then return these segments to the outlet of the measuring unit. During this "liquid transition", the rotation of the two rotors is directly proportional to the flow rate of the liquid thruput. A gear train located outside the measuring unit chamber conveys mechanical rotation of the rotors to a mechanical or electronic register for totalization of liquid thruput.

Flow Capacity

1,000 GPM
227 M³H
1,428 BPH

*Intermittent Flow Capacity

1,200 GPM
272 M³H
1,714 BPH



** 5 hours or less in a 24 hour period.*

WARNING

Do NOT operate this instrument in excess of the specifications listed. Failure to heed this warning could result in serious injury and/or damage to the equipment.

Design Features

- Extremely long service life
- Economical low maintenance
- Two simple rotors with no metal-to-metal contact are the only moving parts in the measuring chamber.
- No oscillating, reciprocating or sliding parts or cranks to wear or disturb the balanced rotary action.
- Conforms with International standards of flowmeter accuracy.

Accessories

- Preset Counters
- Control Valves
- Large Numerical Registers
- Pulse Transmitters
- Ticket Printers
- Strainers



Figure 1 - BiRotor Meter Principle of Operation Diagram

3", 4" and 6" BiRotor Meter Cross Reference

Old Model Number	Max Pressure PSI	Flange Connections	Product Code Selector
B-62DB	150	3" 150 LB. ANSI	B060A
B-63DEB	285	3" 150 LB. ANSI	B061A
B-63DEB	300	3" 300 LB. ANSI	B063A
B-64DEB	740	3" 300 LB. ANSI	B064A
B-65DEB	1480	3" 600 LB. ANSI	B065A
B-72DB	150	3" 150 LB. ANSI	B070A
B-73DEB	285	3" 150 LB. ANSI	B071A
B-73DEB	300	3" 300 LB. ANSI	B073A
B-74DEB	740	3" 300 LB. ANSI	B074A
B-75DEB	1480	3" 600 LB. ANSI	B075A
B-82DB	150	4" 150 LB. ANSI	B080A
B-83DEB	285	4" 150 LB. ANSI	B081A
B-83DEB	300	4" 300 LB. ANSI	B083A
B-84DEB	740	4" 300 LB. ANSI	B084A
B-85DEB	1480	4" 600 LB. ANSI	B085A
BA-89E	285	6" 150 LB. ANSI	BE81A
BA-89E	300	6" 300 LB. ANSI	BE83A

Old Model Number	Max Pressure PSI	Flange Connections	Product Code Selector
B-92DEB	150	6" 150 LB. ANSI	B090A
B-93DEB	285	6" 150 LB. ANSI	B091A
	300	6" 300 LB. ANSI	B093A
B-94DEB	740	6" 300 LB. ANSI	B094A
B-95DEB	1480	6" 600 LB. ANSI	B095A
B-173DEB	285	3" 150 LB. ANSI	B171A
B-173DEB	300	3" 300 LB. ANSI	B173A
B-174DEB	740	3" 300 LB. ANSI	B174A
B-175DEB	1480	3" 600 LB. ANSI	B175A
B-183DEB	285	4" 150 LB. ANSI	B181A
B-183DEB	300	4" 300 LB. ANSI	B183A
B-184DEB	740	4" 300 LB. ANSI	B184A
B-185DEB	1480	4" 600 LB. ANSI	B185A
B-192DEB	150	6" 150 LB. ANSI	B190A
B-193DEB	285	6" 150 LB. ANSI	B191A
B-193DEB	300	6" 300 LB. ANSI	B193A
B-194DEB	740	6" 300 LB. ANSI	B194A
B-195DEB	1480	6" 600 LB. ANSI	B195A

Model Code for 3", 4" and 6" Mechanical BiRotor Meters

CODE	DESCRIPTION							
B	BiRotor Base Code							
	NOTE: INTERMITTENT CAPACITY (Int. Cap.) = 5 Hours or less in a 24 hour period.							
	CODE	STANDARD MAX. FLOWRATE				SIZE		
	06	250 GPM	946 LPM	56 M ³ /HR	357 BPH	3"	DN80	
	Int. Cap.	300 GPM	1135 LPM	68 M ³ /HR	428 BPH	3"	DN80	
	07	425 GPM	1608 LPM	96 M ³ /HR	607 BPH	3"	DN80	
	Int. Cap.	550 GPM	2081 LPM	124 M ³ /HR	785 BPH	3"	DN80	
	08	600 GPM	2271 LPM	136 M ³ /HR	857 BPH	4"	DN100	
	Int. Cap.	800 GPM	3028 LPM	181 M ³ /HR	1142 BPH	4"	DN100	
	E8	800 GPM	3028 LPM	181 M ³ /HR	1142 BPH	6"	DN150	
	Int. Cap.	1000 GPM	3785 LPM	227 M ³ /HR	1428 BPH	6"	DN150	
	09	1000 GPM	3785 LPM	227 M ³ /HR	1428 BPH	6"	DN150	
	Int. Cap.	1200 GPM	4542 LPM	272 M ³ /HR	1714 BPH	6"	DN150	
	APL METERS							
	17	425 GPM	1608 LPM	96 M ³ /HR	607 BPH	3"	DN80	
	18	700 GPM	2649 LPM	158 M ³ /HR	1000 BPH	4"	DN100	
	19	1200 GPM	4542 LPM	272 M ³ /HR	1714 BPH	6"	DN150	
	CODE	MAX. WORKING PRESS./ CONNECTION TYPE						
		Standard	DIN					
	0	150 PSI/150 ANSI	10.3 Bars/PN 16					
	1	285 PSI/150 ANSI	16 Bars/PN 16					
			19.6 Bars/PN 40					
	3	300 PSI/300 ANSI	20.7 Bars/PN 40					
	4	740 PSI/300 ANSI	40 Bars/PN 40					
			51 Bars/PN 64					
	5	1480 PSI/600 ANSI	64 Bars/PN 64					
			100 Bars/PN 100					
	CODE	REVISION LEVEL						
	A	Initial Release						
	CODE	METER OUTPUT REGISTRATION						
	C	Mechanical Output-Gallons/ ^o F			H	Mechanical Output- M ³ / ^o C		
	D	Mechanical Output-Liters/ ^o C			J	Mechanical Output-BBL/ ^o F		
	E	Mechanical Output-Litres/ ^o C			K	Mechanical Output-Pounds/ ^o F		
	F	Mechanical Output-Decaliters/ ^o C			L	Mechanical Output-Kilograms/ ^o C		
	G	Mechanical Output-Decalitres/ ^o C						
	CODE	MATERIALS: HOUSING / ELASTOMERS						
	A	Steel/Viton						
	C	Steel/Teflon (Dynamic) Nitrile (Static)						
	CODE	CONNECTION TYPE / SPECIAL						
	A	Standard Connection - 125-250 AARH				M	DIN 2501 PN 64, DIN 2526 Form E	
	J	DIN 2501 PN 16, DIN 2526 Form C				N	DIN 2501 PN 100, DIN 2526 Form E	
	L	DIN 2501 PN 40, DIN 2526 Form C						
	CODE	HOUSING OPTIONS						
	A	Standard			F	Vertical Mount		
	B	Thermowell			G	Heating Jacket Hsg & Thermowell Hsg		
	C	Heating Jacket Housing			H	Heating Jacket Hsg, Cover & Thermowell Hsg		
	E	Heating Jacket Housing & Cover			J	Gauge Tap Up/Down Stream		

CODE		TEMPERATURE / ROTORS				
A	-20 to 150°F (-29 to 66°C)	Standard Rotors		E	-20 to 150°F (-29 to 66°C) Cast Iron Rotors	
B	150 to 200°F (66 to 93°C)	Extra Clearance Rotors		F	150 to 200°F (66 to 93°C) Cast Iron Extra Clearance Rotors	
C	200 to 325°F (93 to 163°C) (1)	Extra Clearance Rotors		G	200 to 325°F (93 to 163°C) Cast Iron Extra Clearance Rotors (1)	
D	325 to 450°F (163 to 232°C) (2)	Cast Iron Extra Clearance Rotors				
CODE		ADJUSTOR / ATC				
CODE	No Adjustor	4200 Adjustor	100% Gearing	ATC LOW COEFF GEN. PROD. .0003 TO .0008F (.0005 TO .001C)	ATC HIGH COEFF GEN. PROD. .0005 TO .0020F TO .004C) (.001	ATC LOW COEFF CRUDE .0003 TO .0008F (.0005 TO .001c)
A	X					
C		X				
E			X			
J		X		X		
K		X			X	
L			X			X
P		X				X
CODE		REGISTRATION				
C	None			L	Series 10 Register/.1 Unit	
D	Large Dial Register/Whole Units			M	Series 10 Register/.01 Units	
E	Large Dial Register/Whole Units 1/10			N	Stack Monitor With Series 10 Register / 1 Pulse Per Unit	
F	Large Dial Register/Whole Units, Accumulative Printer			P	Stack Monitor With Series 10 Register / 10 Pulses Per Unit	
G	Large Dial Register/Whole Units 1/10, Accumulative Printer			Q	Large Dial Register/Whole Units, Accumulative Printer OIML	
H	Large Dial Register/Whole Units, Zero Start Printer			R	Large Dial Register/Whole Units, Zero Start Printer OIML	
J	Large Dial Register/Whole Units 1/10, Zero Start Printer			S	Large Dial Register/Whole Units 1/10, Accumulative Printer OIML	
K	Series 10 Register/Whole Units			T	Large Dial Register/Whole Units 1/10, Zero Start Printer OIML	
CODE		REGISTER COUNTER ACCESSORIES				
A	None					
B	4-Figure Mechanical Preset					
C	5-Figure Mechanical Preset					
D	4 Figure Mechanical Preset With SPDT Switch (UL/CSA or CENELEC EEx d IIA T6)					
E	5 Figure Mechanical Preset With SPDT Switch (UL/CSA or CENELEC EEx d IIA T6)					
K	Right Angle Drive For 1,000 Pulses Per Unit (Pulse Transmitter Not Included)					
L	Right Angle Drive For 8,400 Pulses Per Unit (Pulse Transmitter Not Included)					
M	Right Angle Drive For 10,000 Pulses Per Unit (Pulse Transmitter Not Included)					
CODE		ADDITIONAL ACCESSORIES				
A	None					
B	Impulse Contactor/1 Pulse Per Revolution					
C	Impulse Contactor/10 Pulses Per Revolution					
D	Dual Channel HFPG/100 pulses/revolution					
E	Dual Channel HFPG/1000 pulses/revolution					
F	7697 Single Channel Pulser/1 Pulse Per Revolution - Mounted on Register (UL/CSA or CENELEC EEx d IIA T6)					
G	7697 Single Channel Pulser/10 Pulses Per Revolution - Mounted on Register (UL/CSA or CENELEC EEx d IIA T6)					
H	7671 Single Channel Pulser/100 Pulses Per Revolution - Mounted on Register (UL/CSA or CENELEC EEx d IIA T6)					
J	Counter Extension, 7-1/2" (19 cm)					
K	Counter Extension, 3 FT. (91 cm)					
L	Counter Extension, 6 FT. (183 cm)					
W	7671 Dual Channel 50 Pulses Per Revolution Pulser - Mounted on Register (UL/CSA or CENELEC EEx d IIA T6)					
X	ISPG - 10 Dual Channel 10 Pulses Per Revolution Pulser - mounted on Accessory Block (CENELEC EEx ib IIC T6 and IP-55)					
Y	ISPG - 100 Dual Channel 100 Pulses Per Revolution Pulser - mounted on Accessory Block (CENELEC EEx ib IIC T6 and IP-55)					
1	7697 Single Channel Pulser/1 Pulse Per Revolution - Mounted on Accessory Block (UL/CSA or CENELEC EEx d IIA T6)					
2	7697 Single Channel Pulser/10 Pulses Per Revolution - Mounted on Accessory Block (UL/CSA or CENELEC EEx d IIA T6)					
3	7671 Dual Channel 50 Pulses Per Revolution Pulser - Mounted on Accessory Block (UL/CSA or CENELEC EEx d IIA T6)					
4	7671 Single Channel Pulser/100 Pulses Per Revolution - Mounted on Accessory Block (UL/CSA or CENELEC EEx d IIA T6)					
CODE		DOCUMENTATION AND APPROVALS				
A	None					
C	NACE with Material Test Report (See General Section for QA Documents)					
D	Material Test Report (See General Section for QA Documents)					
F	CENELEC					
G	CENELEC/Material Test Report (See General Section for QA Documents)					
H	CENELEC/NACE with Material Test Report (See General Section for QA Documents)					

Ordering Information

In order to accurately process an order, such information as product to be metered, product viscosity, product temperature range, ambient temperature range, rate of flow, operating pressure, units of registration, accessories required, and optional features needed must be specified by the customer.

Materials of Construction

Housing: Welded Steel Construction Combining Steel Castings and Drawn Steel Plate

Measuring Unit:

Rotors: Aluminum (Standard)

Rotor Shafts: E.T.D. 150

Rotor Bearings: Stainless Steel

Body and End Covers: Cast Iron

Counter Base Plate:

Body: Steel

O-Ring: Viton (Standard)

Drive Shafts, Drive Gears, and Ball Bearings: Stainless Steel

Typical Pressure Drop Curve

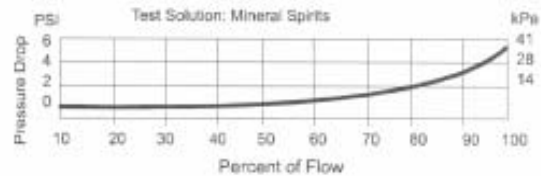

Typical Accuracy Curve

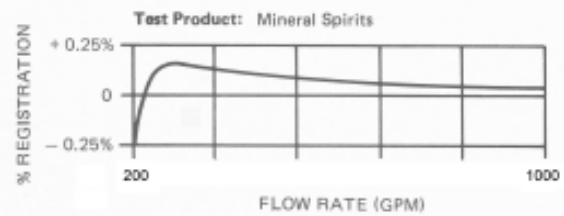

Flange Connections

Model	Connections	Max Working Pressure @100F	DIN Connections	Max Working Pressure
B090	6" 150 lb. ANSI	150 PSI	DN 80 PN 16	10.3 Bar
B091	6" 150 lb. ANSI	285 PSI	DN 80 PN 16	16 Bar
B093	6" 300 lb. ANSI	300 PSI	DN 80 PN 40	19.6 Bar
B094	6" 300 lb. ANSI	740 PSI	DN 80 PN 40	20.7 Bar
			DN 80 PN 64	40 Bar
			DN 80 PN 64	51 Bar
B095	6" 600 lb. ANSI	1480 PSI	DN 80 PN 64	64 Bar
			DN 80 PN 100	100 Bar

Temperature Range: -20F to 150F (-29C to 66C) Optional 450F (232C)

Shipping Weight and Volume (Approximate)	
B090, B091	650 lbs. @ 20.2 Cu. Feet 295 kgs. @ .57 Cu. Meters
B093	758 lbs. @ 21.4 Cu. Feet 344 kgs. @ .78 Cu. Meters
B094	1393 lbs. @ 27.7 Cu. Feet 632 kgs. @ .78 Cu. Meters
B095	1495 lbs. @ 30 Cu. Feet 678 kgs. @ .85 Cu. Meters

Typical Minimum Flow Rates

Meter Models B090, B091, B093, B094, B095	Viscosity		
	1.25 cSt.	6.25 cSt.	
	Accuracy +/- 0.25%	Accuracy +/- 0.25%	
Maximum Flow Rate	Minimum Flow Rates		
GPM	1000	100	50
M ³ H	227	23	12
BPH	1428	142	72

Dimensions (For Certified Dimensional Prints - Consult Factory)

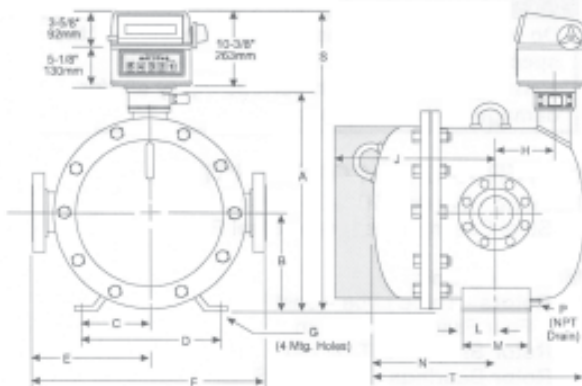

Model	mm	Dimensions														
	Inches	A	B	C	D	E	F	G	H	J	L	M	N	P	S	T
B090	mm	781	352	216	432	387	762	22	268	673	102	203	414	-	1060	764
B091	Inches	30 3/4	13 7/8	8 1/2	17	15 1/4	30	7/8	10 9/16	26 1/2	4	8	16 5/16	1 1/2	41 3/4	30 1/16
B093	mm	794	352	216	432	387	784	22	268	698	102	203	422	-	1063	768
B093	Inches	31 1/4	13 7/8	8 1/2	17	15 1/4	30 7/8	7/8	10 9/16	27 1/2	4	8	16 5/8	1 1/2	41 7/8	30 1/4
B094	mm	822	381	195	381	368	879	22	268	762	102	203	470	-	1091	886
B094	Inches	32 3/8	15	17 11/16	15	14 1/2	34 5/8	7/8	10 9/16	30	4	8	18 1/2	3/8	43	34 15/16
B095	mm	822	381	195	381	381	914	22	268	787	102	203	514	-	1091	930
B095	Inches	32 3/8	15	17 11/16	15	15	36	7/8	10 9/16	31	4	8	20 1/4	1 1/2	43	36 5/8



SERV' INSTRUMENTATION

Mesure et Contrôle vos fluides

ZI Broteau Nord

69540 Irigny

TEL 33 (0)4 78 51 47 50

FAX 33 (0)4 78 51 59 96

<http://www.servinstrumentation.fr>

The contents of this publication are presented for informational purposes only, and while every effort has been made to ensure their accuracy, they are not to be construed as warranties or guarantees, express or implied, regarding the products or services described herein or their use or applicability. Brodie Meter Co., LLC reserves the right to modify or improve the designs or specifications of such products at any time without notice.